

© Oaklands Environmental Ltd 2024 We reserve the right to change specification without prior notice in line with our policy of continuous development.

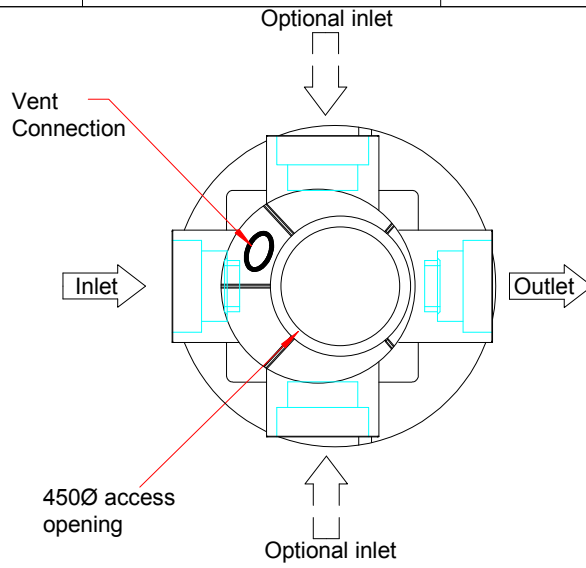

Area Drained: 1950 m²
 Nominal Size: 3.5
 Flow Rate: 3.5 Litre/sec
 Peak Flow: 35 Litre/sec
 Connections: 110 - 160 Ø mm
 Oil Storage: 52.5 litres
 Capacity: 1140 litres
 Diameter: 1260 mm
 Approx Height: 1965 mm

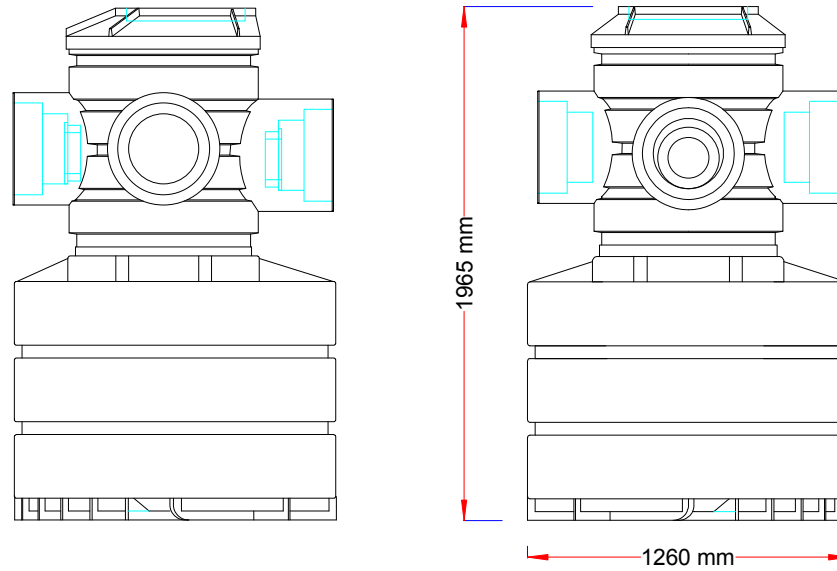

sales@oaklandsenvironmental.com
 www.oaklandsenvironmental.com

REV	DETAIL		
2	New 1209 base added		
3	Geceptor top & ribbed base		
4	Radius added to outer ribs		

TITLE	NSB3.5 General arrangement drawing
CUSTOMER	

DRAWING NO	GA1001/24	SCALE	NOT TO SCALE
THIRD ANGLE PROJECTION		SHEET	
		1 of 1	
TOLERANCE +/- 2%		REV	4