



CAT 5 Packaged Booster Set

Fixed and Variable

From Direct Pumps and Tanks

Table of Contents

Product Overview Variable.....	2
Product Overview Fixed	3
CAT5 Booster Set Suitablility.....	4
CAT5 Booster Set Features.....	5
•	
187 Technical Drawings.....	6
251 Technical Drawings.....	7
305 Technical Drawings.....	8
375 Technical Drawings.....	9
Pump Curves and Technical Information.....	10



CAT 5 Variable Booster Set

Product Overview

- ▶ Simple 'plug and play' installation
- ▶ Fast to install little to connect
- ▶ Variable speed pump
- ▶ Fully CAT 5 compliant
- ▶ WRAS approved GRP storage tank
- ▶ WRAS approved 3/4" high flow ball valve fitted
- ▶ WRAS and British Water compliant
- ▶ Easy access through the standard door
- ▶ 1 Phase 230 volt supply
- ▶ Low water level protection



CAT 5 Fixed Booster Set



Product Overview

- ▶ Simple 'plug and play' installation
- ▶ Fast to install little to connect
- ▶ Fixed speed pump
- ▶ Fully CAT 5 compliant
- ▶ WRAS approved GRP storage tank
- ▶ WRAS approved 3/4" high flow ball valve fitted
- ▶ WRAS and British Water compliant
- ▶ Easy access through the standard door
- ▶ 1 Phase 230 volt supply
- ▶ Low water level protection



DPT Tank Sizes Available

- ▶ 187 litre
- ▶ 251 litre
- ▶ 305 litre
- ▶ 375 litre

All DPT tanks are designed and built in the United Kingdom for superior quality.

MADE IN
BRITAIN

The DPT CAT 5 Variable and Standard Booster Set

The DPT CAT5 Booster Set is available in either a standard or variable configuration, each booster set comes with a single pump and a range of tank sizes from 187L up to 375L.

The DPT CAT5 Booster Set is the ideal solution small spaces with a footprint of only 670mm x 610mm.

- ▶ Whisper quiet pump with a noise level rating of less than 50db.
- ▶ Four standard tank sizes on offer, 187L, 251L, 305L, and 375L are available.
- ▶ Compact design with small footprint on all models
- ▶ WRAS approved GRP storage tank
- ▶ WRAS approved 3/4" ball valve fitted as standard
- ▶ Suitable for single phase 230 volt supply only
- ▶ A standard opening offers unobstructed access to the system
- ▶ Low water level protection
- ▶ Maximum allowable static head is 12 meters.





CAT 5 Booster Set Features at a Glance



DPT CAT 5 187 Fixed

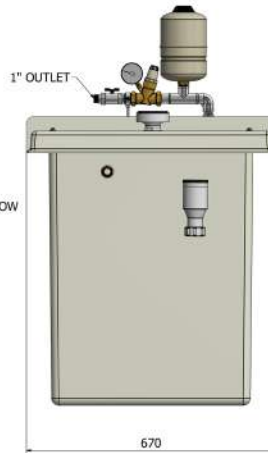
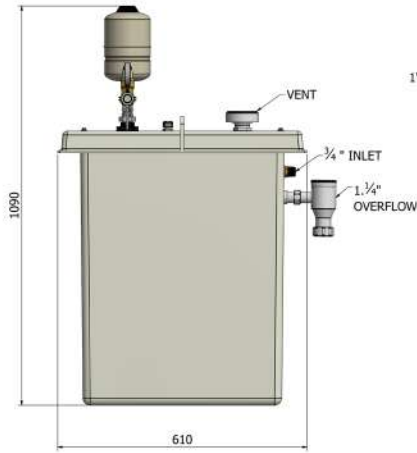
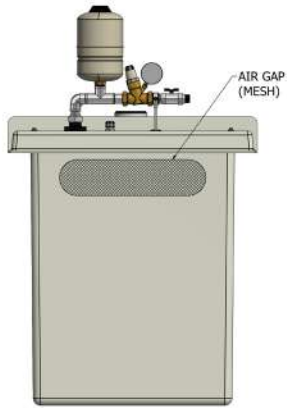
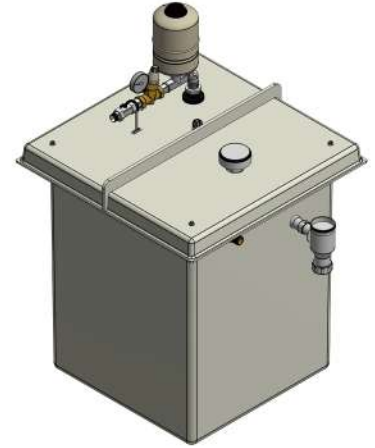
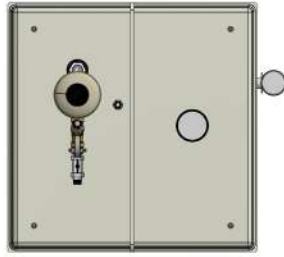

Technical Specification

- Single Pump Packaged Booster Set and CAT5 Break Tank.
- Fixed Speed Pressure Pump - Variable speed optional upon request.
- Pre-assembled for easy installation.
- Wet/Pressure tested prior to despatch.
- Quiet operation, less than 50 decibels.
- Compact design, narrow width ideal for access through doorways.
- WRAS Approved water storage tank manufactured from GRP with 25mm insulation.
- WRAS Approved $\frac{3}{4}$ " High flow ball valve fitted.
- 1 Phase 230 Volt supply.
- Low Water Level Protection.
- WRAS Approved fully adjustable system pressure reducing valve fitted.
- **Maximum allowable static head 12 metres.**

DPT CAT 5 187 Variable

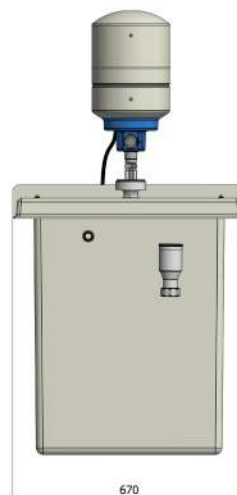
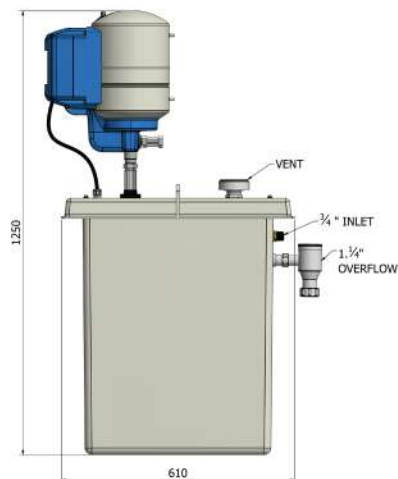
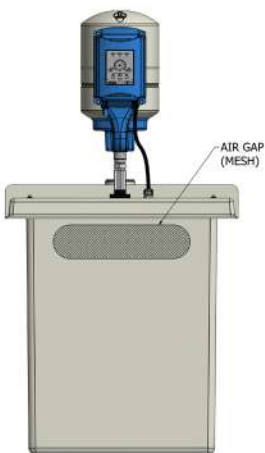
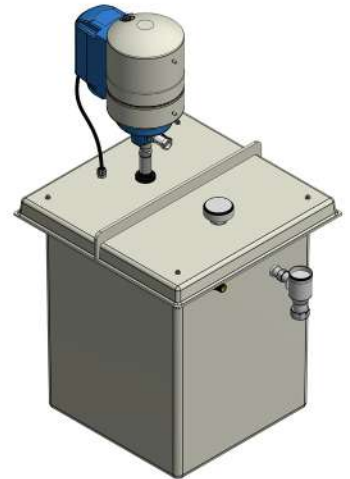

DPT CAT 5 251 Fixed

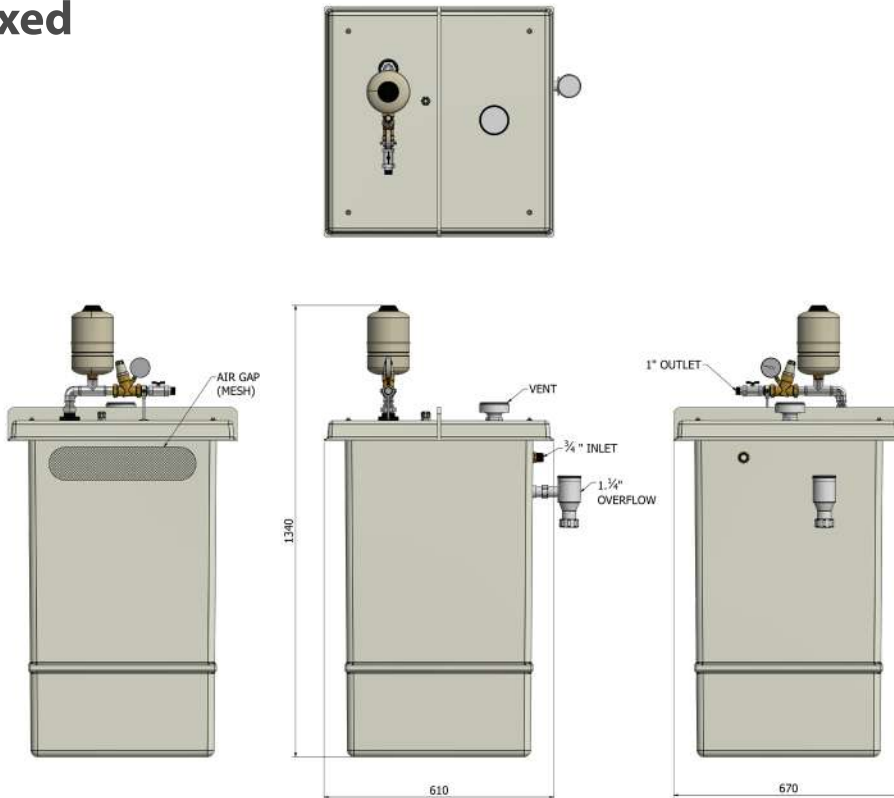

Technical Specification

- Single Pump Packaged Booster Set and CAT5 Break Tank.
- Fixed Speed Pressure Pump - Variable speed optional upon request.
- Pre-assembled for easy installation.
- Wet/Pressure tested prior to despatch.
- Quiet operation, less than 50 decibels.
- Compact design, narrow width ideal for access through doorways.
- WRAS Approved water storage tank manufactured from GRP with 25mm insul
- WRAS Approved 3/4" High flow ball valve fitted.
- 1 Phase 230 Volt supply.
- Low Water Level Protection.
- WRAS Approved fully adjustable system pressure reducing valve fitted.
- **Maximum allowable static head 12 metres.**

DPT CAT 5 251 Variable

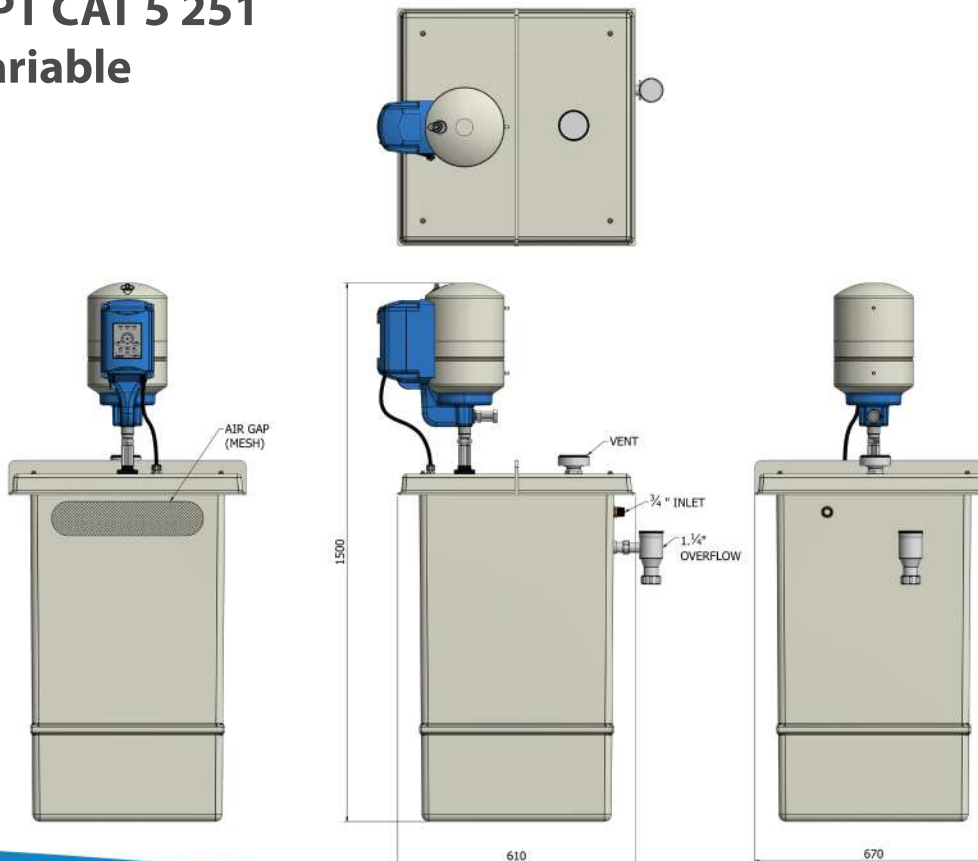

DPT CAT 5 301 Fixed

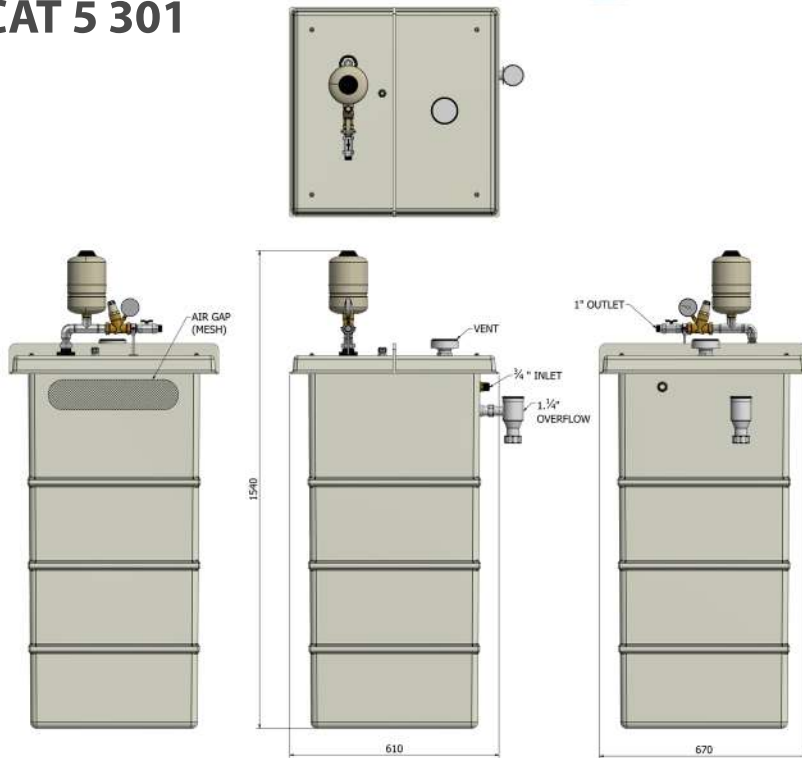

Technical Specification

- Single Pump Packaged Booster Set and CAT5 Break Tank.
- Fixed Speed Pressure Pump - Variable speed optional upon request.
- Pre-assembled for easy installation.
- Wet/Pressure tested prior to despatch.
- Quiet operation, less than 50 decibels.
- Compact design, narrow width ideal for access through doorways.
- WRAS Approved water storage tank manufactured from GRP with 25mm insulation.
- WRAS Approved $\frac{3}{4}$ " High flow ball valve fitted.
- 1 Phase 230 Volt supply.
- Low Water Level Protection.
- WRAS Approved fully adjustable system pressure reducing valve fitted.
- **Maximum allowable static head 12 metres.**

DPT CAT 5 301 Variable

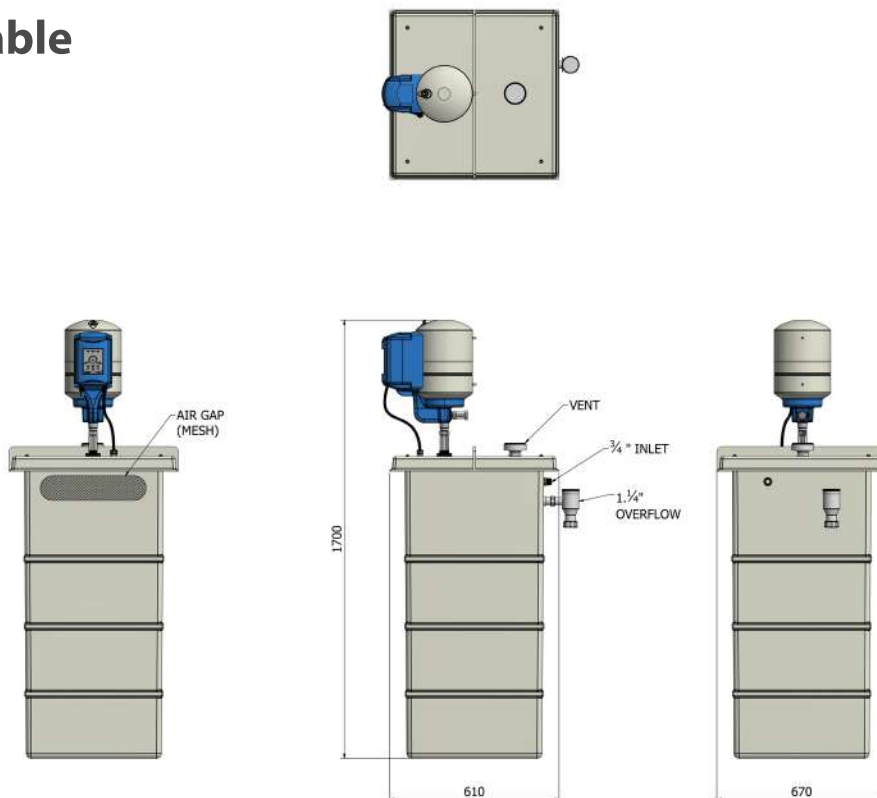

DPT CAT 5 375 Fixed

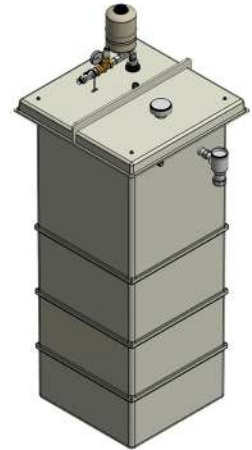
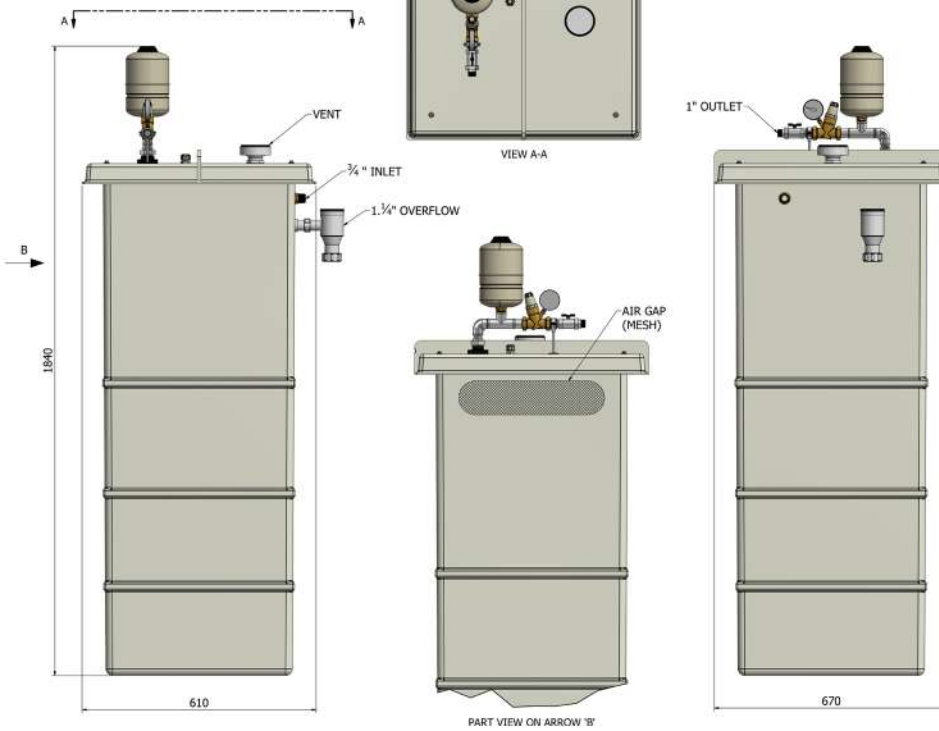

Technical Specification

- Single Pump Packaged Booster Set and CATS Break Tank.
- Fixed Speed Pressure Pump - Variable speed optional upon request.
- Pre-assembled for easy installation.
- Wet/Pressure tested prior to despatch.
- Quiet operation, less than 50 decibels.
- Compact design, narrow width ideal for access through doorways.
- WRAS Approved water storage tank manufactured from GRP with 25mm insulation.
- WRAS Approved 3/4" High flow ball valve fitted.
- 1 Phase 230 Volt supply.
- Low Water Level Protection.
- WRAS Approved fully adjustable system pressure reducing valve fitted.
- **Maximum allowable static head 12 metres.**

DPT CAT 5 375 Variable

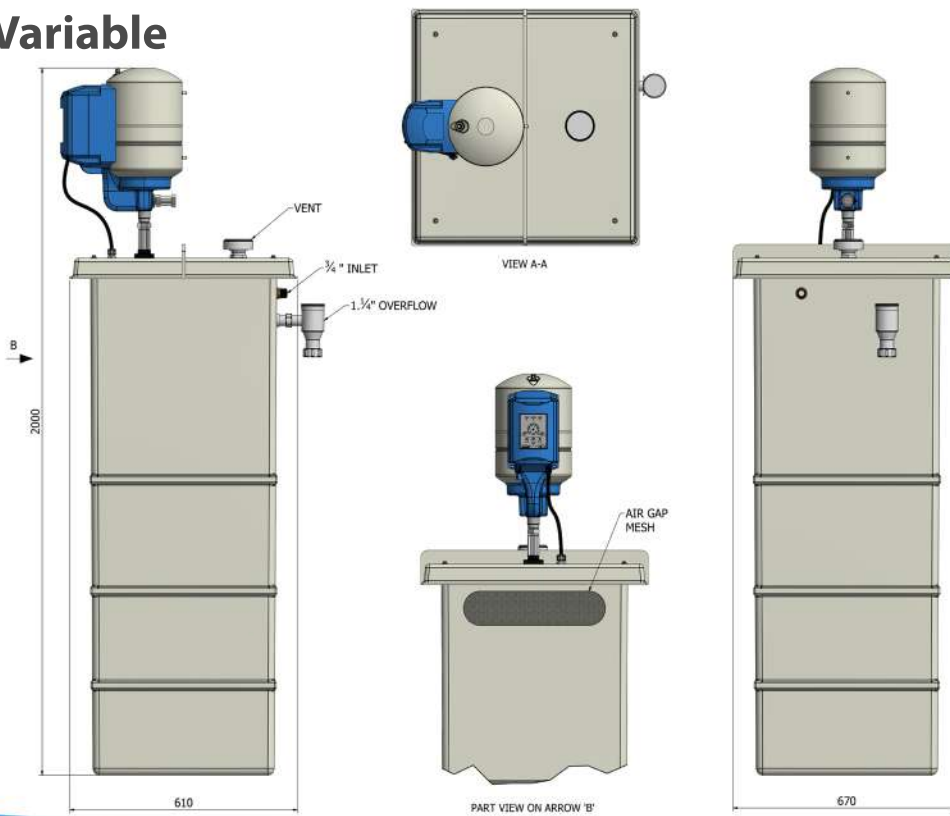



CAT5 Pump Curves

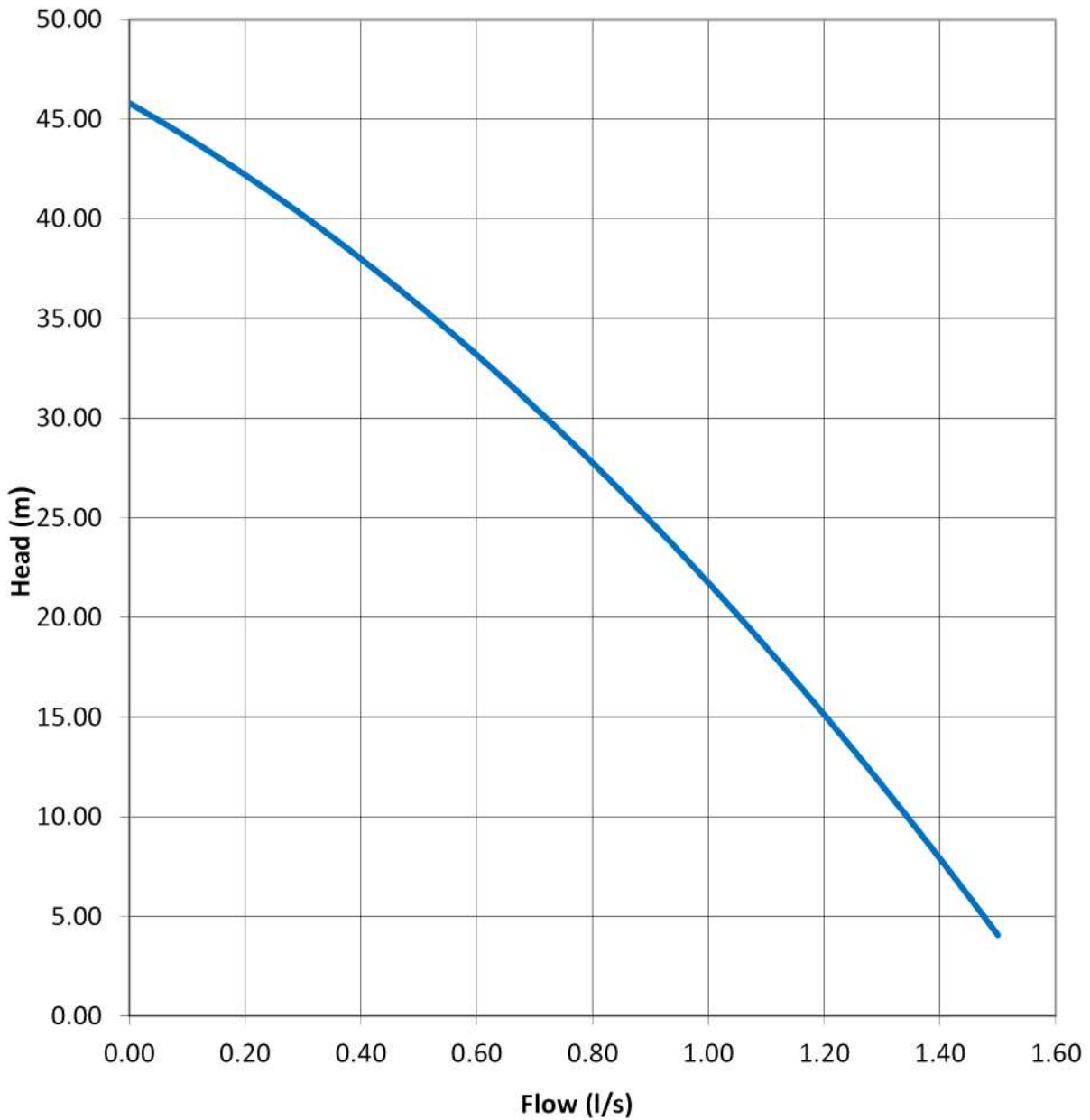

CAT5 Technical Data

Model	Kw	F.L.C. Amps	Inlet Connection DN1	Overflow Connection DN2	Outlet Connection DN3	Width Mm (W)	Length Mm (L)	Height Mm (H)
DPT CAT5 187	0.75	4.8	3/4"	1 1/4"	1"	670	610	1090
DPT CAT5 251	0.75	4.8	3/4"	1 1/4"	1"	670	610	1340
DPT CAT5 305	0.75	4.8	3/4"	1 1/4"	1"	670	610	1540
DPT CAT5 375	0.75	4.8	3/4"	1 1/4"	1"	670	610	1840



Direct Pumps and Tanks Ltd
Unit 12 Cossal Industrial Estate
Ilkeston
Derbyshire
DE7 SUA
Tel: 0115 9444474
Fax: 0115 9442040
Email: info@dpandt.co.uk