

Notes:

1. This drawing is for 'Dimensional Information Only', It is essential that this drawing is read in conjunction with the 'Installation Guidelines' supplied with the unit. (Copies available from our sales department).
2. All Pipe connections are \varnothing 110.0mm PVCu.
3. All units require appropriate 'Cover' & 'Frame' to suit site loadings (standard cover supplied).
4. Blower assembly mounted externally, within 10m of treatment plant.
5. \varnothing 160mm Inlet Option - By Exyernal Adaptor Only.

Unit Dimension Chart								
Unit	Dim 'A' (mm)	Dim 'B' (mm)	Dim 'C' (mm)	Dim 'D' (mm)	Dim 'E' (mm)	Dim 'F' (mm)	Dim 'G' (mm)	Unit Weight (Kgs)
E006G10AB	1000	1100	1200	1100	2200	1850	500	250
E006G15AB	1500	1600	1200	1100	2700	1850	500	270
E009G10AB	1000	1100	1700	1600	2700	1850	500	275
E009G15AB	1500	1600	1700	1600	3200	1850	500	295
E012G10AB	1000	1100	1700	1600	2700	1850	500	275
E012G15AB	1500	1600	1700	1600	3200	1850	500	295

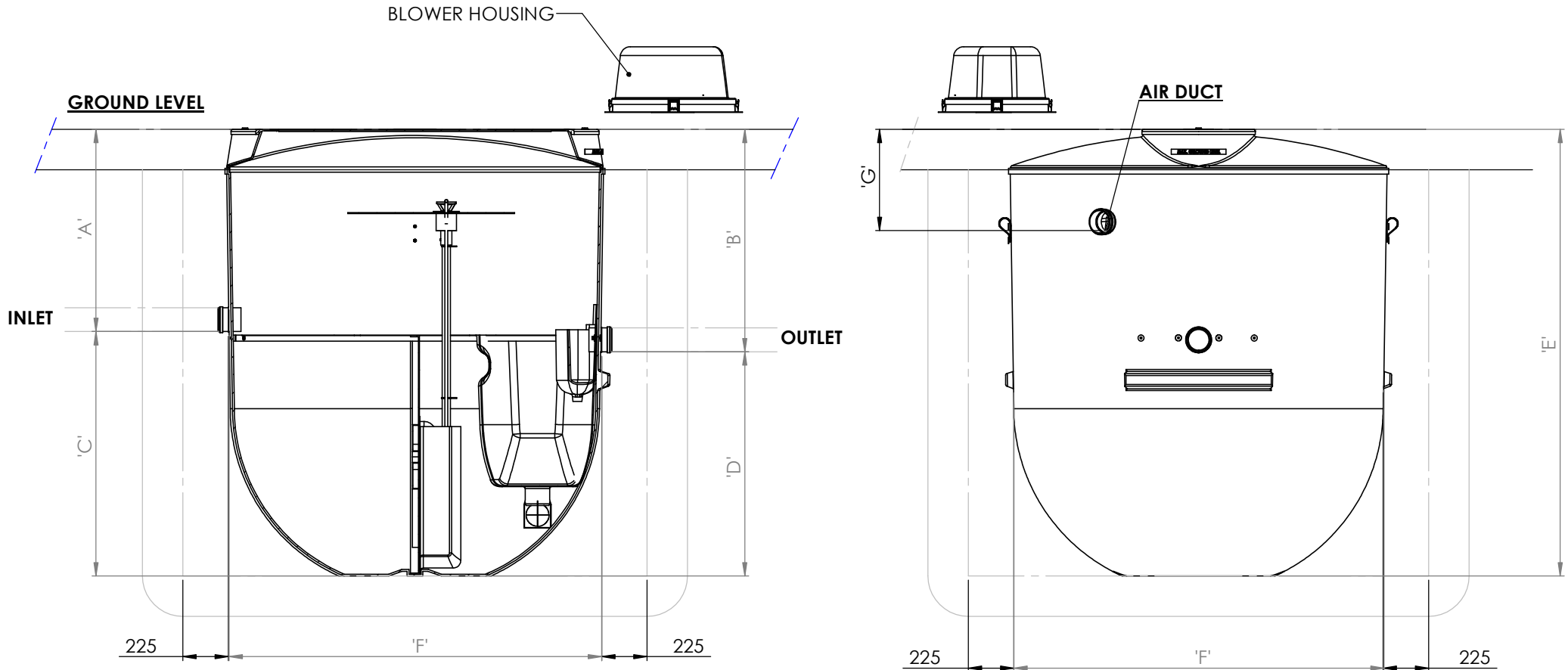

Please check with Clearwater that this drawing is the latest issue			
Issue	Date	Drawn by	Description
08	02.06.20	Viaasan K	CC1523
07	17/05/18	M.H.	CC1435

Material : Various
Finish :
Weight : 270.53 Kg Kgs

Tolerance :
Thickness : n/a
Surface Area :

Drawing : DS0968B - E6, E9 & E12 Gravity
E6, E9 & E12 Treatment Plant (Gravity)

All dimensions in mm	Scale: Not to scale
----------------------	---------------------

Clearwater reserve the right to alter the details of this drawing without prior notice. This drawing is copyright and may not be reproduced or used without the written permission of Clearwater.

