

MAINSBOOST VariQ

Variable Speed Boost Pump

The Mainsboost VariQ offers a variable speed, intelligent, energy efficient and quiet water boosting pump.

The Mainsboost VariQ is designed to boost water performance from a cold water storage tank, roof tank or ground tank in domestic and light commercial applications and is ideal for many properties with up to 3 floors and up to 10 outlets in operation simultaneously.

Even if multiple outlets, showers and appliances are running at the same time, the speed of the pump will adjust automatically to meet demand without any noticeable drop in water pressure.



Features

- Boosts pressure up to 5.5 bar
- Boosts flow rate up to 97 litres/min
- Variable speed intelligent control
- Quiet operation
- Illuminated touch screen and control panel
- Easy to install and commission
- Self priming up to 4 metres
- Dry run protection
- Continuously rated
- 2 year warranty

Application

- Boosting water pressure and flow from a cold water storage tank in domestic and small commercial applications.

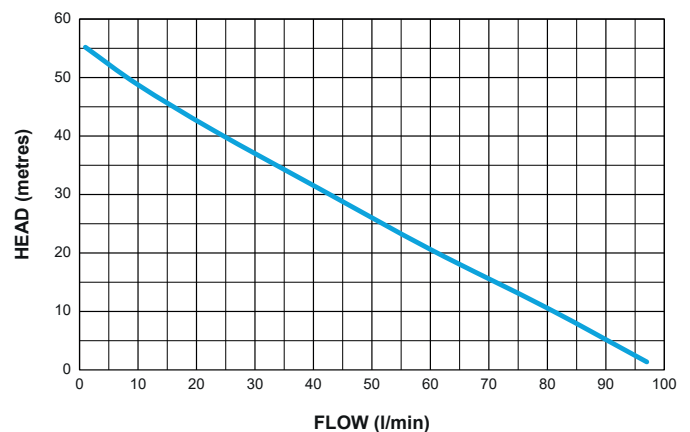

Model		Mainsboost VariQ 47322
General	Warranty	2 years
	Certification	UKCA, CE
Features	Pump type	Centrifugal Multistage
	Pump control	Variable speed
	Inlet strainer	Optional
	Flexible connection hoses	Optional
	Dry run protection	✓
	Priming vent plug	✓
	Self priming	✓
	Typical noise	From 51 dB(A)
Performance	Maximum head – closed valve	55 metres
	Performance @ 60 litres/min	20.4 metres
	Performance @ 80 litres/min	10.2 metres
	Maximum flow	97 litres/min
	Maximum static inlet pressure	10 metres
	Maximum static outlet pressure	12 metres
	Maximum working pressure	650 kPa (6.5 bar)
	Maximum ambient air temperature (continuous)	45°C
	Min / Max water temperature	Min 4°C / Max 60°C
	Maximum suction lift	4 metres (foot-valve and strainer fitted)
Connections	Pump connections	G1 F
Motor	Motor type	Permanent magnet variable frequency
	Duty rating	Continuous (S1)
Electrical	Power supply (Vac/Ph/Hz)	230 V a.c. / 1 / 50 Hz
	Power consumption – P1 (Watts)	665 Watts
	Current – full load	2.9 Amps
	Fuse rating	5 Amps
	Power cable length	1.5 metres
Physical	Enclosure protection	IPX4
	Length (excluding hose)	391 mm
	Width	194 mm
	Height (excluding hose)	292 mm
	Weight (including fittings)	8.32 Kg

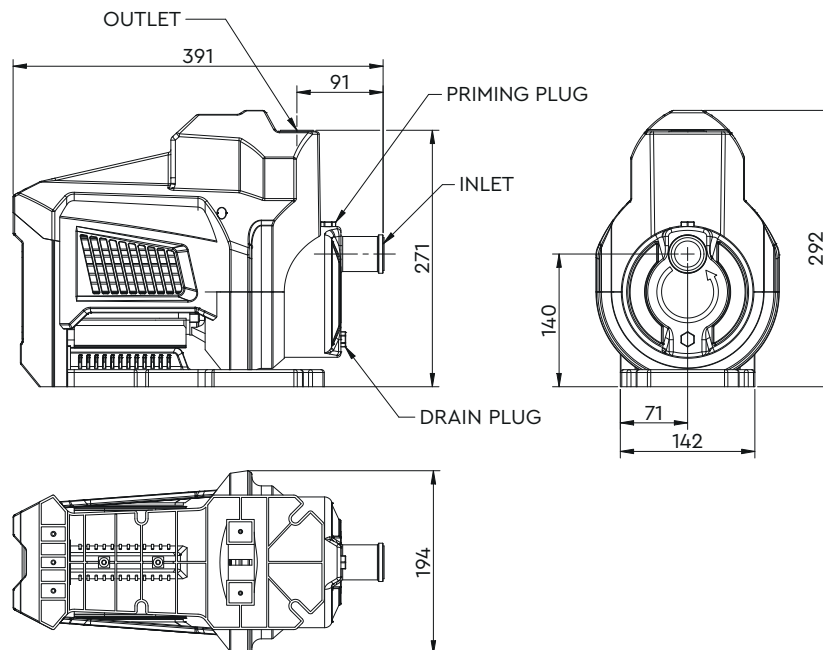

Stuart Turner Limited reserves the right to amend specifications without notice.

Stuart Turner Ltd, Henley-on-Thames, Oxfordshire RG9 2AD Tel: +44 (0) 1491 572655 Fax: +44 (0) 1491 573704

TechAssist Helpline +44 (0) 800 31 969 80

www.stuart-turner.co.uk

Pt. No. 21253 Issue 0422-02-01