

MAINSBOOST

Flomate MBF Pumps Installation & Maintenance Instructions

Please leave this instruction booklet with the owner as it contains important guarantee, maintenance and safety information



Read this manual carefully before commencing installation.

This manual covers the following products:

MBF 60-1-15
Pt. No. 46631

MBF 80-1-15
Pt. No. 46634



PRODUCT DESCRIPTION

Electric motor driven peripheral pump with bypass, complete with an automatic control system consisting of flow switch, pressure vessel and electronic control.

APPLICATION

The Mainsboost Flomate pumps are a mains booster unit with an automatic control system for domestic use, designed to assist the pressure from the mains supply, where the mains pressure is insufficient. This unit requires a minimum unassisted supply flow of 0.6 l/min at the outlet to operate.

The pump is limited to producing a maximum flow of not greater than 12 l/min, and a maximum pressure of 3.2 bar.

When the flow/pressure from the rising main exceeds the pump output, the **patented** integral bypass will direct the water into the system as normal.

The Flomate mains booster is a patent granted design.

STORAGE

If this product is not to be installed immediately on receipt, ensure that it is stored in a dry, frost and vibration free location in its original packaging.

CONTENTS

	Page
Checklist5
Important Facts – read before commencing installation6
Location7
Electrical Installation9
Priming11
Maintenance11
Technical Specification12
Trouble Shooting13
Guarantee16

WARNINGS:



- This pump must not be used for any other application without the written consent of Stuart Turner Limited.
- The pump is not suitable for heavy commercial/ industrial applications.
- This appliance can be used by children aged from 8 years and above and persons with reduced physical, sensory or mental capabilities or lack of experience and knowledge if they have been given supervision or instruction concerning use of the appliance in a safe way and understand the hazards involved.
- Children shall not play with the appliance.
- Cleaning and user maintenance shall not be made by children without supervision.
- Maximum head (closed valve) 32 metres.
- The motor casing can become very hot under normal operating conditions. Care must be taken to ensure it cannot be touched during operation.



- The electrical installation must be carried out in accordance with the current national electrical regulations.
- The electrical installation must be installed by a qualified person.
- In the interests of electrical safety a 30 mA residual current device (R.C.D. not supplied) should be installed in the supply circuit. This may be part of a consumer unit or a separate unit.
- Before starting work on the electrical supply ensure power supply is isolated.
- DO NOT allow the supply cord to contact hot surfaces, including the motor shell, pump body or pipework. The cord should be safely routed and secured by cable clips.



- This appliance must be earthed via the supply cord, which must be correctly connected to the earth point located in the terminal box.
- The supply cord and internal wiring within the terminal box are routed and secured to ensure compliance with the electrical standard EN 60335-1. It is essential that prior to any disturbance of this internal wiring, all cable routing and securing details are carefully noted to ensure re-assembly to the same factory pattern is always maintained.
- If the supply cord is to be changed or is damaged, it must be replaced with a special cord assembly available from Stuart Turner or one of their approved repairers.

Notes



- This product must be installed in accordance with the current Water Supply (Water Fittings) Regulations.
- Under no account should the internal flow restrictor be removed, or replaced with an alternative design.
- Care must be taken to ensure the maximum pressure generated by the pump combined with the incoming mains water pressure does not exceed the pumps maximum operating pressure of 4.5 bar.

Please read installation details carefully as they are intended to ensure this product provides long, trouble free service. Failure to install the unit in accordance with the installation instructions will lead to invalidation of the warranty.

CHECKLIST

IMPORTANT: With the pump removed from its packaging check for any damage prior to installation. If any damage is found contact Stuart Turner Ltd within 24 hours of receipt.

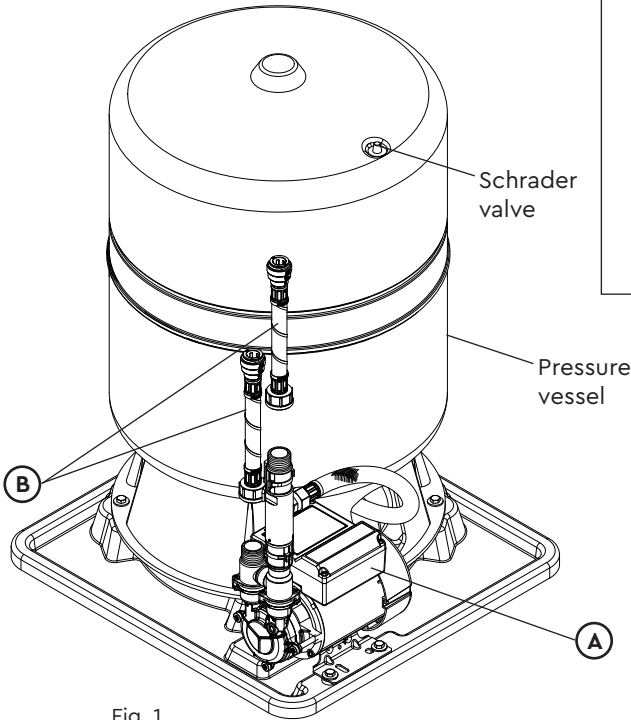

Fig. 1

Item	Description	Qty	Item	Description	Qty
(A)	Pump unit	1	(D)	Pressure gauge	2
(B)	Flexible hoses	2	(E)	Valve, strainer, check valve combined	1
(C)	Pressure regulating valve	1	(F)	Adapter G ¼ " to G ½ "	1

Your product may vary slightly from the picture above.

Cont ...

1 IMPORTANT FACTS: READ BEFORE COMMENCING PUMP INSTALLATION

A Water temperature

The water entering the pump must be controlled as follows:

- 1.11 The maximum allowable water temperature is 35 °C.
- 1.12 The minimum allowable water temperature is 4 °C.

B Pipework – General

- 1.13 **Secure pipework:** Ensure pipework to and from pump is independently supported & clipped to prevent forces being transferred to inlet and outlet branches of pump.
- 1.14 **Flux:** Solder joints must be completed and flux residues removed prior to pump installation (**flux damage will void any warranty**).
- 1.15 **Pipework design:** Care should be taken in the design of pipework runs to minimize the risk of air locks e.g. use drawn bends rather than 90° bends.



- 1.16 **DO NOT** introduce solder flux to flexible hoses, pump or pump parts.
- 1.17 **DO NOT** allow contact with oil or cellulose based paints, paint thinners or strippers, acid based descalents or aggressive cleaning agents.
- 1.18 **Water flow:** An un-assisted flow rate of at least 0.6 l/min is required through the outlets to be pumped in order to make this pump work.

C Plumbing Installation Regulations

- 1.19 The plumbing installation must comply with the current water and building regulations.

2 LOCATION – GENERAL



- 2.11 **Access:** For emergencies and maintenance the pump must be easily accessible.
- 2.12 **Protection:** The pump must be located in a dry position, frost free and protected from freezing. Ensure the pump is in a dry position, away from heat sources, such as radiators and heaters.
- 2.13 **Ventilation:** Ensure an adequate air flow to cool the pump. Separate the pump from other appliances that generate heat. An 80 mm air gap must be maintained to allow free air flow through the fan cowl and over the motor at all times.
- 2.14 **Safety:** The motor casing can become very hot under normal operating conditions. Care must be taken to ensure it cannot be touched during operation.
- 2.15 **Water retention:** Site the pump in a location where in the unlikely event of a water leak, any spillage is contained or routed to avoid electrics or areas sensitive to water damage.
- 2.16 **Location point:** The pump **must** be located directly after the mains water stopcock. Site on a smooth level floor of sufficient strength to support the filled weight of the Mainsboost Flomate (see Section 6 – Technical Specification for filled weight). **Do not** site the pump in the roof space, since air locks can easily result.
- 2.17 **Direction of flow:** Ensure the water flow is in the direction of the arrow, as marked on the flow switch reed clamp.

2.18 Pipework Connections:



Isolating valves: Always install isolating valves (not supplied) to both suction and delivery pipe to aid future maintenance.

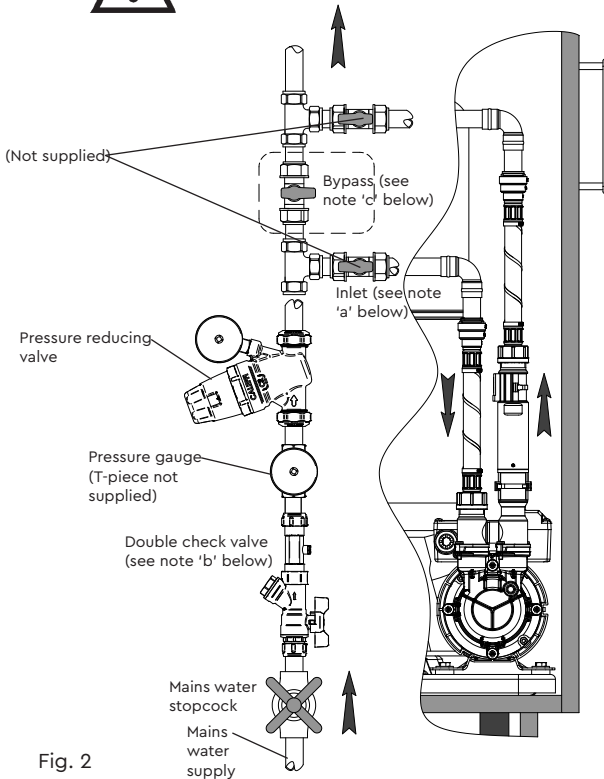

Fig. 2

- a) A pressure regulator (set at 2.0 bar) must be fitted, to ensure the maximum working pressure of the pump is not exceeded.
- b) To meet the requirements of the Water Supply (water fittings) Regulations, a type EC – verifiable double check valve must be fitted.
- c) It is advisable to fit a bypass pipe and isolating valves. This will allow removal of the pump for maintenance and servicing, and ensure the water supply into the property is still available during that period (Fig. 3).

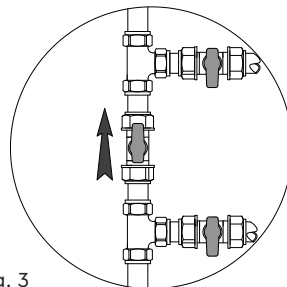
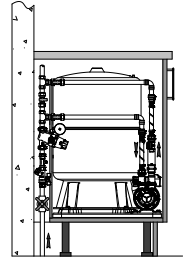
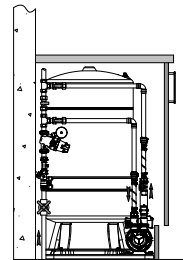

Fig. 3

Typical installation
Mains Boost Extra 60
(in cupboard)



Typical installation
Mains Boost Extra 80
(in cupboard on the floor)



Cont ...

3 ELECTRICAL INSTALLATION / EARTHING



- 3.11 **Regulations:** The electrical installation must be carried out in accordance with the current national electrical regulations and installed by a qualified person.
- 3.12 **Safety:** In the interests of electrical safety a 30 mA residual current device (**R.C.D. not supplied**) must be installed in the supply circuit. This may be part of a consumer unit or a separate unit.
- 3.13 Before starting work on the electrical installation ensure the power supply is isolated.
- 3.14 The motor and wiring must not be exposed to water.
- 3.15 The supply cable must be positioned so that it is not stepped on, cut or damaged.
- 3.16 **Electrical Connection:**
- The pump is provided with a factory fitted supply cord.
 - This must be permanently connected to the fixed wiring of the mains supply.
 - Means for disconnection must be incorporated in the fixed wiring in accordance with the wiring regulations.
 - A suitable method of connection would be via a dedicated double pole switched, fused connection unit complying with BS 1363-4, protected with a fuse (see technical specification section).
 - The connection unit should be mounted in an easily accessible position and should be labelled if confusion is possible, to allow easy identification of the flomate isolating switch.
- 3.17 **Earthing:** This appliance must be earthed via the supply cord, which must be correctly connected to the earth point located in the terminal box.
- 3.18 **Additional earthing:** Certain installations may require additional earthing arrangements such as equipotential bonding. Reference should be made to the relevant regulations concerning this subject to ensure compliance.
- 3.19 **Wiring Of Connection Unit:**



WARNING: This appliance must be earthed.

The wires in the mains lead (supply cord) are coloured in accordance with the following code:

Green and Yellow: Earth

Blue: Neutral

Brown: Live

As the colours of the wires in the mains lead of this appliance may not correspond with the coloured markings identifying the terminals in your connection unit proceed as follows:

- The wire which is coloured green and yellow must be connected to the terminal in the connection unit which is marked with the letter E or by the earth symbol: \oplus or coloured green or green and yellow.
- The wire which is coloured blue must be connected to the terminal which is marked with the letter N or coloured black.
- The wire which is coloured brown must be connected to the terminal which is marked with the letter L or coloured red.

3.20 Wiring Diagram:



The supply cord and internal wiring within the terminal box are routed and secured to ensure compliance with the electrical standard EN 60335-1. Do not disturb the internal wiring or factory routing and securing of all internal wiring.

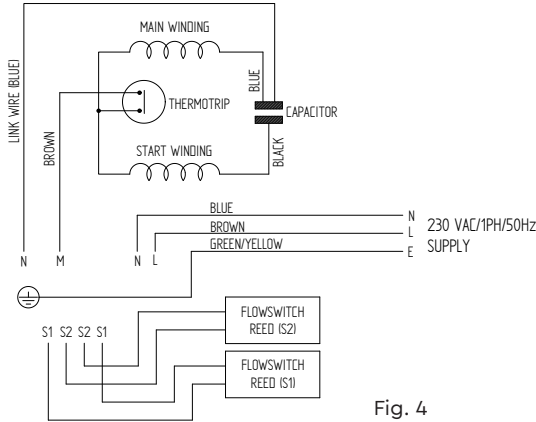

Fig. 4

3.21 Fuse:

Model	Fuse Size (AMPS)
All Models	5

3.22 Supply Cord Replacement:



The supply cord and internal wiring within the terminal box are routed and secured to ensure compliance with the electrical standard EN 60335-1. It is essential that prior to any disturbance of this internal wiring, all cable routing and securing details are carefully noted to ensure re-assembly to the same factory pattern is always maintained.

If the supply cord is to be changed or is damaged, it must be replaced with a special cord assembly available from Stuart Turner or one of their approved repairers.

On disassembly note the cord retention and routing system. Re-assemble to the same pattern.

For information on cable connection consult the wiring diagram and cable gland fitting instructions.

3.23 Cable Gland Fitting Instructions:

To enable correct assembly of the cable gland the 'O'-ring (Fig. 5 item 1) must be placed over the cable before the clamping insert (Fig. 5 item 2) can be tightened.

Note: Cable diameter range:- 6.5 mm to 9.5 mm.

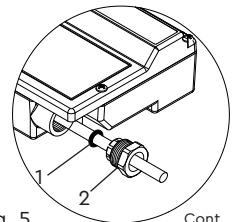

Fig. 5

Cont ...

4 PRIMING

- 4.11 **Priming:** This pump unit is self venting. Open the mains stopcock and allow the pump to fill and vent, please note the pump chamber must be full of liquid at all times. Seal damage will result if the pump runs dry.
- 4.12 **Starting:**
- Ensure all outlets are closed, turn power supply 'on'.
 - Open and close all outlets in turn associated with the pump allowing liquid to flow from each outlet until all air is purged.
 - The pump will run on while this is being completed until the vessel is full.
 - Any tap or control valve within the system when opened and closed will now turn the pump on & off. Check system for leaks, if clear the system is now operating correctly
 - Carefully check pump and pipework for leaks whilst pump running and stationary before leaving the installation unattended.
- Note: It is normal for the pump to run on after all outlets have been closed. This gives the pump chance to re-fill the vessel ready for next use.
- 4.13 **For Further Technical Support:** Phone the Stuart Turner TechAssist team on +44 (0) 800 31 969 80. Our staff are trained to help and advise you over the phone.

5 MAINTENANCE

- 5.11 Disconnect electrical supply before working on pump.
- 5.12 Turn off liquid supplies to the pump and release pressure by opening outlets before attempting maintenance.
- 5.13 Should ever the need arise for the vessel to have its air charge checked or replenished, it should be carried out as follows: –
- Isolate pump electrically.
 - Isolate the mains water supply via the stop valve.
 - Release system water pressure by opening a system outlet (tap).
 - Check air charge at Schrader valve (Fig. 1) using a tyre pressure gauge.

Model	Vessel Pressure		
	KpA	bar	psi
All models	150	1.5	22

- Replenish air charge if required by injecting air into the vessel via the Schrader valve using a car or bicycle pump, ensuring a system outlet valve (tap) remains open during this procedure to allow the vessel to exhaust any excess water.
- Close all system taps, open the mains stop valve, turn on electrical power.

6 TECHNICAL SPECIFICATION

Pump Model		MBF 60-1-15 46631	MBF 80-1-15 46634
General	Guarantee	3 years	
	WRAS approval	1412081	
	Approvals	WRAS, CE	
Features	Pump type	Peripheral	
	Flexible hoses	2	2
	Pressure vessel size	60 litre	80 litre
	Pressure vessel water capacity	30 litre	40 litre
	Upstream line-in kit	15 mm	
	Dry run protection	✓	✓
	Noise	from 46 dB(A)	
Materials	Pressure vessel	Epoxy coated steel	
	Membrane	Butyl rubber	
	Pump body	Brass	
	Impeller	Brass	
	Mechanical seal	EPDM / PTFE / Al. Oxide	
Performance	Maximum head (closed valve)	3.2 bar (32 metres)	
	Maximum flow	16 l/min	
	Maximum working pressure*	450 kPa (4.5 bar)	
	Maximum ambient air temperature	40 °C	
	Min / Max water temperature	Min 4 °C / Max 35 °C	
	Flow switch sensitivity (approx)	0.6 l/min	
Connections	Pump connections	G ¾ male	
Flexible hoses	Connections	G ¾ female x 15 mm push-in x 200 mm long	
Motor	Type	Induction (thermal trip/auto reset)	
	Duty rating	Continuous (S1)	
Electrical	Power supply / phase / frequency	230 V a.c. / 1 / 50 Hz	
	Power consumption	365 Watts	
	Current (full load)	1.7 Amps	
	Fuse rating	5 Amps	
	Power cable (pre-wired)	1.5 metres	
Physical	Enclosure protection	IPX4	
	Width	480 mm	
	Depth	457 mm	
	Height (excluding hoses)	663 mm	852 mm
	Dry Weight (including fittings)	19.7 Kg	23.9 Kg
	Filled Weight (maximum)	49.7 Kg	63.9 Kg

Stuart Turner reserve the right to amend the specification in line with its policy of continuous development of its products.

*Note: The maximum pressure that can be applied to the pump under any installation conditions.

6.11 **Noise:** The equivalent continuous A-weighted sound pressure level at a distance of 1 metre from the pump does not exceed 70 dB(A).

7 TROUBLE SHOOTING GUIDE

Symptoms	Probable Cause	Recommended Action
Pump will not start.	No water. Water supply. Electrical supply. Reed switch is faulty and low water demand. Faulty reed switch/PCB Internal motor thermotrip activated.	Check required flow of liquid is available to the fittings through outlets of approx. 0.6 l/min. Check water supply from mains and all stopcocks are open. Check wiring connections. If flow exists inline with requirements – check that all electric switches are on. Is the correct fuse fitted? Check circuit breaker is set. Does the pump start when flow is above 4 l/min? If yes refer to circuit test as detailed in 7.11. Refer to circuit test as detailed in 7.11. Wait for thermotrip to auto reset and check that duty point and run time is within specification (see Technical Section).
Pump starts when outlets are off. or Pump cycles (hunts) on/off frequently.	Leak in system	Check tap washers, w/c valve washers, pipe joints.
Pump runs on when all terminal outlets are closed.	Leak in system. Reed clamp out of position. Jammed flow switch. Faulty reed switch or P.C.B. Pressure vessel not full of water.	Check tap washers, w/c valve washers, pipe joints. Ensure reed clamp is fitted correctly in location groove (Fig. 5). Remove flow switch reed clamps whilst pump is running. If pump stops proceed to isolate the pump electrically and hydraulically and remove brass housing that contains float. Check for free movement. Remove flow switch reed clamps whilst pump is running. If pump continues to run, this indicates a closed circuit in either the flow switch reed or P.C.B. in the terminal box, these should be checked electrically. Wait for vessel to fill (approx 5.5 mins for 60 litre and 8 mins for the 80 litre).
Pump will not start and poor performance.	No water supply and faulty upper reed switch.	Check required flow of liquid is available to the fittings of approx. 0.6 l/min. Check water supply from mains and all stopcocks are open. Refer to circuit test as detailed in 7.11.
Pump does not run on to fill vessel	Lower reed switch is faulty.	Refer to circuit test as detailed in 7.11.

Cont ...

7.11 Flow Switch Circuit Test:

1. First confirm visually that neither of the flow switch reed clamps have been dislodged during handling or installation. The clamps must be fully located within their flow switch body grooves as shown.
2. To carry out the following test you will need to obtain a magnet, a typical fridge magnet is suitable.
3. Ensure the power supply is switched on.
4. Position the magnet directly in front of a reed clamp as shown. If pump does not start, then slowly move the magnet up and down to a position that exceeds the extent of the reed clamp. The pump should instantaneously start at some point during this extent of movement. If this does not happen, this indicates a possible fault with the reed switch or the P.C.B which is located within the terminal box. These should be checked electrically. Consult Stuart Turner for further instructions.
5. Repeat step 4 with the second reed clamp.

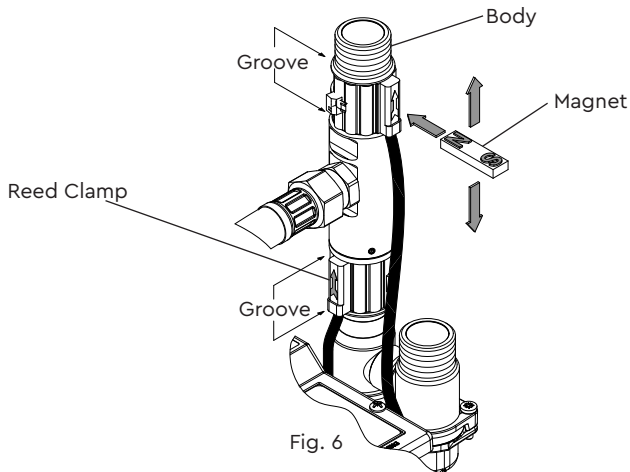

- 7.12 **Fault Finding:** The PCB is also fitted with a "power on" indicator light. This will remain illuminated when mains power is supplied to the board. The indicator light is located on the PCB within the terminal box.



This operation should only be carried out by a competent person

To view the light the following procedure must be followed:-

- Isolate the mains electrical power supply from the pump.
- Remove the four screws retaining the terminal box lid (Fig. 7).
- Lift the terminal box lid off.

Cont ...

- **IMPORTANT** – Ensure there is no contact with any of the internal parts of the terminal box.
- Briefly reconnect the mains power supply to the pump – the 'power on light should illuminate if the pump has been correctly wired.
- Isolate the mains electrical power supply from the pump.
- Re fit the terminal box lid ensuring no cables are trapped.
- Re fit the four terminal box lid retaining screws, tighten to 0.8 Nm.

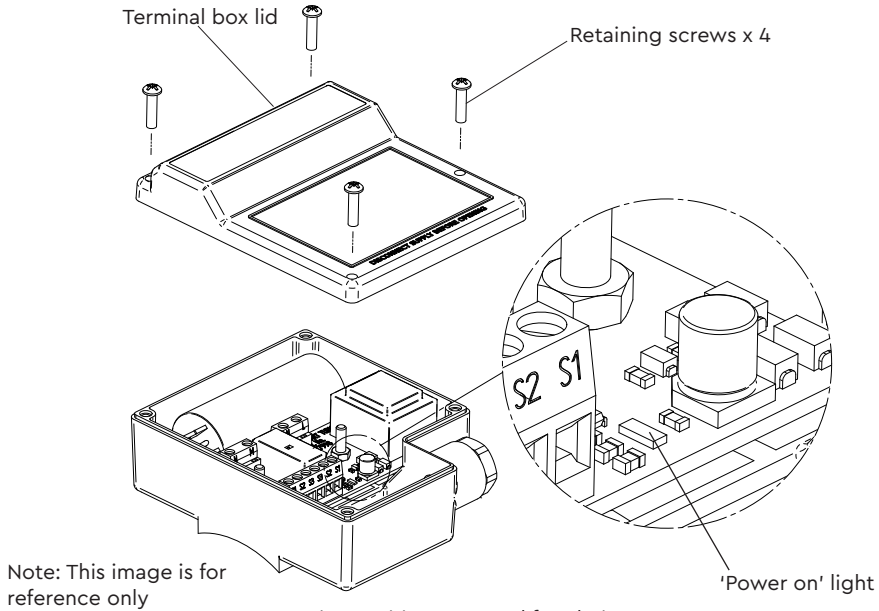

Fig. 7 Wiring removed for clarity

7.13 **Environment Protection:** Your appliance contains valuable materials which can be recovered or recycled. At the end of the products' useful life, please leave it at an appropriate local civic waste collection point.

8 THE MAINSBOOST FLOMATE GUARANTEE

Congratulations on purchasing a Stuart Turner pump.

We are confident this pump will provide many years of trouble free service as all our products are manufactured to the very highest standard.

The Mainsboost Flomate pump is guaranteed to be free from defects in materials or workmanship for 3 years.

Within the guarantee period we will repair, free of charge, any defects in the pump resulting from faults in material or workmanship, repairing or exchanging the whole unit as we may reasonably decide.

Not covered by this guarantee: Damage arising from incorrect installation, improper use, unauthorised repair, normal wear and tear and defects which have a negligible effect on the value or operation of the pump.

Reasonable evidence must be supplied that the product has been purchased within the guarantee term prior to the date of claim (such as proof of purchase or the pump serial number).

This guarantee is in addition to your statutory rights as a consumer. If you are in any doubt as to these rights, please contact your local Trading Standards Department.

In the event of a claim isolate the unit and then please telephone '**TechAssist**'.

+44 (0) 800 31 969 80

Proof of purchase should accompany the returned unit to avoid delay in investigation and dealing with your claim.

You should obtain appropriate insurance cover for any loss or damage which is not covered by Stuart Turner Ltd in this provision.

Please record here for your records.

TYPE NO.	SERIAL NO.	DATE PURCHASED

NOTES

NOTES

NOTES



DECLARATION OF CONFORMITY

Machinery Directive – 2006/42/EC

BS EN 12100, BS EN 809

Low Voltage Directive – 2014/35/EU

BS EN 60335-1, BS EN 60335-2-41

EMC Directive – 2014/30/EU

BS EN 55014-1, BS EN 55014-2, BS EN 61000-3-2, BS EN 61000-3-3,
BS EN 61000-4-2, BS EN 61000-4-3, BS EN 61000-4-4, BS EN 61000-4-5, BS EN 61000-4-6,
BS EN 61000-4-11

EMF Directive – 1999/519/EC

BS EN 62233

RoHs Directive – 2011/65/EU

WEEE Directive – 2012/19/EU

IT IS HEREBY CERTIFIED THAT THE STUART ELECTRIC MOTOR DRIVEN PUMP AS SERIAL NUMBER BELOW, COMPLIES WITH THE ESSENTIAL REQUIREMENTS OF THE ABOVE E.E.C. DIRECTIVES.



RESPONSIBLE PERSON
AND MANUFACTURER

STUART TURNER LIMITED
HENLEY-ON-THAMES, OXFORDSHIRE
RG9 2AD ENGLAND.

Signed  Technical Director

Stuart Turner are an approved company to BS EN ISO 9001:2015



Stuart Turner Ltd, Henley-on-Thames, Oxfordshire RG9 2AD ENGLAND

Tel: +44 (0) 1491 572655, Fax: +44 (0) 1491 573704

info@stuart-turner.co.uk www.stuart-turner.co.uk