

The Agrimax Pump System

The Agrimax submersible cutter pump is designed for heavy duty agricultural waste water applications, with a pumped media free passage of 25mm at temperatures up to 40°C.

It features a stainless steel cutter ring and scroll type cutter impeller mounted on a reduced length shaft. Single phase models are supplied with a float switch as standard (manual versions to order) and an IP55 control box housing start and run capacitors, thermal overload and reset.

- ▶ EN-GJL-250 cast iron construction
- ▶ Mechanical seal - silicon carbide
- ▶ Lip seal and O-rings in NBR
- ▶ Oil chamber
- ▶ Continuous duty motors, Class H insulation suitable for >15 starts per hour
- ▶ Bearings are over dimensioned, life lubricated, maintenance free
- ▶ 10 metres Neoprene HO7RN-F cable as standard
- ▶ Guiderail versions available.

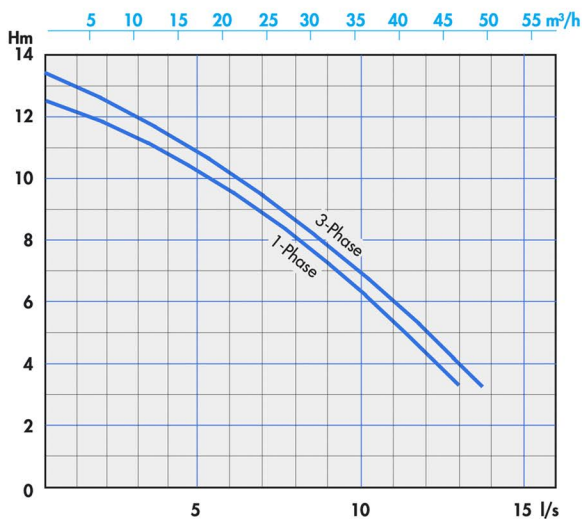
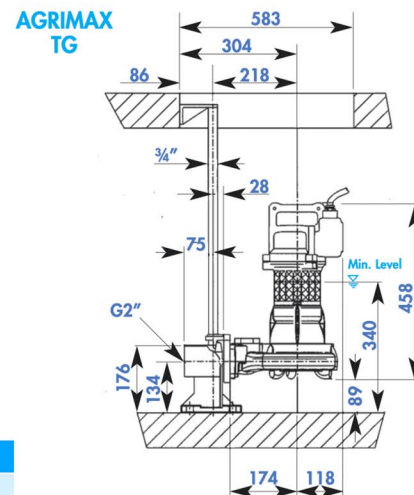
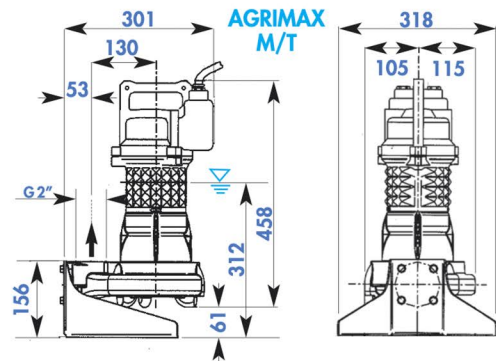

Model	Power	Nom kW	Nom Amps	RPM	mm-Free Passage	Weight Kg
AGRIMAX-M	230/1/50	1.8	10.0	2850	25	42
AGRIMAX-T	400/3/50	2.4	5.0	2850	25	37
AGRIMAX-TG	400/3/50	2.4	5.0	2850	25	47