

© Oaklands Environmental Ltd 2024. We reserve the right to change specification without prior notice in line with our policy of continuous development.

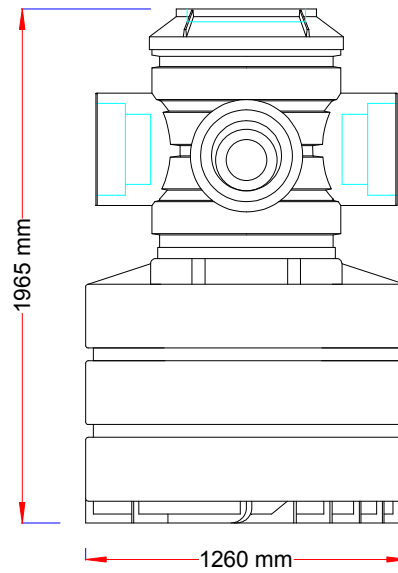

Area Drained:	3300 m <sup>2</sup>
Nominal Size:	6
Flow Rate:	6 Litre/sec
Peak Flow:	60 Litre/sec
Connections:	110 - 160 Ø mm
Oil Storage:	90 litres
Capacity:	1140 litres
Diameter:	1260 mm
Approx Height:	1965 mm

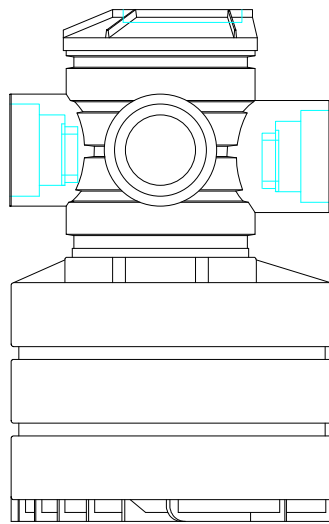
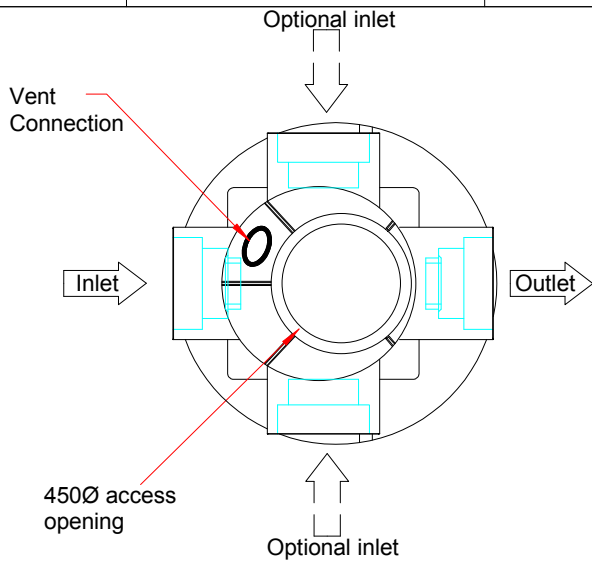

sales@oaklandsenvironmental.com  
www.oaklandsenvironmental.com

REV	DETAIL		
2	New 1209 base added		
3	Geoceptor top & ribbed base		
4	Radius added to outer ribs		

TITLE	NSB6 General arrangement drawing
CUSTOMER	

DRAWING NO	GA1061/24	SCALE	NOT TO SCALE
THIRD ANGLE PROJECTION		SHEET	1 of 1
		TOLERANCE +/- 2%	REV 4