

25mm Encapsulated
RHS Steel Braxcing

250

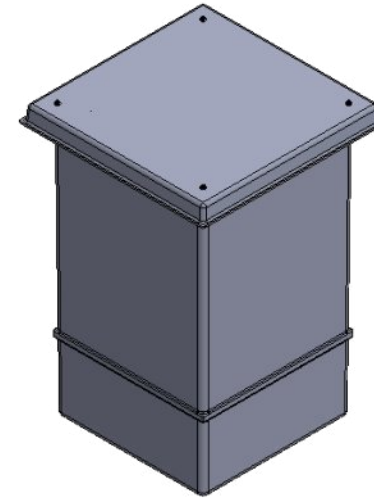

TITLE
PW251.INS.AG

DRAWN BY C.MORRIS DATE 05/10/2017

CUSTOMER CUSTOMER

NOTE:

All Tanks Direct tanks must be fully supported on a flat,level & continuous foundation providing structural support to the tank when full to maximum operating capacity. It is essential that the user refers to the conditions of installation document prior to the installation of the tank. Under no circumstances should the tank body be used to provide support to pipework and ancillary items. The tank lid is a structural part of the tank and must be in place and fitted correctly when water is contained within the tank.

ALL DIMENSIONS+/- 5mm
UNLESS OTHERWISE STATED

DESCRIPTION:

PW251 one piece cold water storage tank
suitable for AG/AF Air gap

A4

ALL DIMENSIONS IN MM - DO NOT SCALE

DATE	VERSION	NOTES
04/10/2017	A	FIRST ISSUE

TANK SPECIFICATION :

INTERNAL DIMENSIONS	500 x 500 x 1000mm
EXTERNAL DIMENSIONS	690 x 690 x 1009mm
NOM. CAPACITY	250 Litres
DRY WEIGHT	20 KG
INSULATION THICKNESS	25mm
WRAS CERT. NUMBER	131006
MATERIAL	GRP



SCALE:1:20

SHEET 1 OF 1