

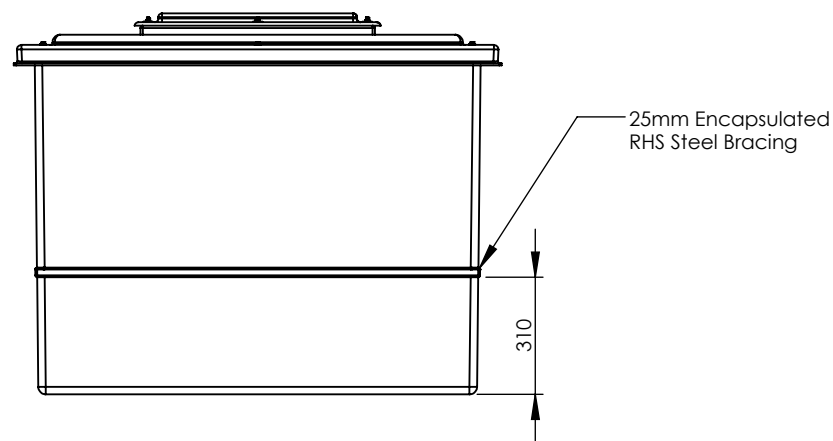

3D Image
Scale 1:25

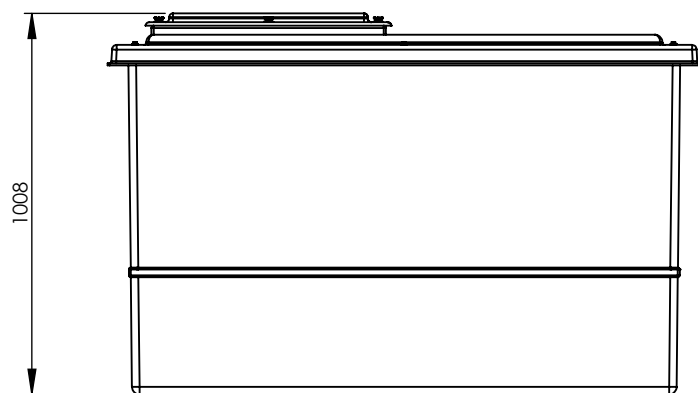
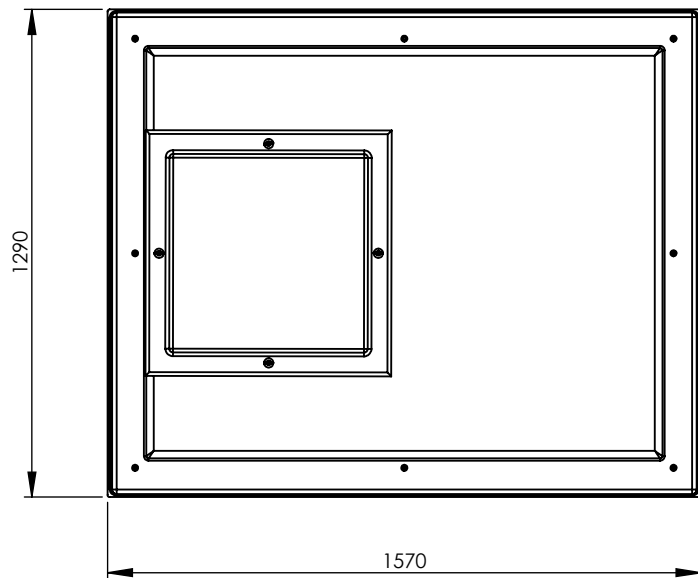
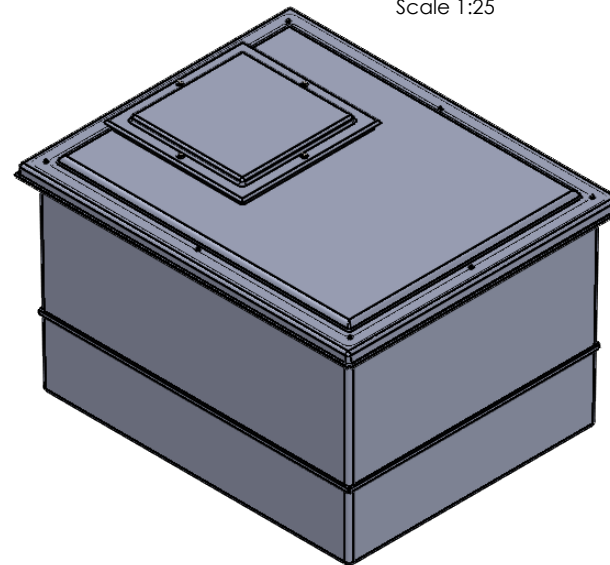

TITLE
PW1364.INS.AG

DRAWN BY **C.MORRIS** DATE **27/11/2017**

CUSTOMER
CUSTOMER

NOTE:
All Tanks Direct tanks must be fully supported on a flat, level & continuous foundation providing structural support to the tank when full to maximum operating capacity. It is essential that the user refers to the conditions of installation document prior to the installation of the tank. Under no circumstances should the tank body be used to provide support to pipework and ancillary items. The tank lid is a structural part of the tank and must be in place and fitted correctly when water is contained within the tank.

ALL DIMENSIONS +/- 5mm UNLESS OTHERWISE STATED

DESCRIPTION:
PW1364 one piece cold water storage tank suitable for AG/AF Air gap

A4

ALL DIMENSIONS IN MM - DO NOT SCALE

DATE	VERSION	NOTES
28/09/2017	A	FIRST ISSUE

TANK SPECIFICATION :	
INTERNAL DIMENSIONS	1370 x 1092 x 915mm
EXTERNAL DIMENSIONS	1570 x 1290 x 1008mm
NOM. CAPACITY	1364 Litres
DRY WEIGHT	81 KG
INSULATION THICKNESS	25mm
WRAS CERT. NUMBER	1310072
MATERIAL	GRP



SCALE:1:20 SHEET 1 OF 1