

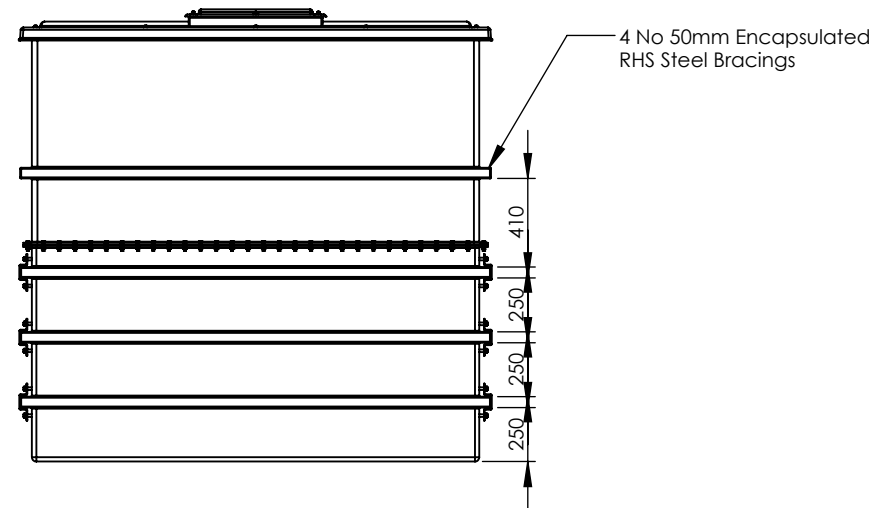

3D Image
Scale 1:50

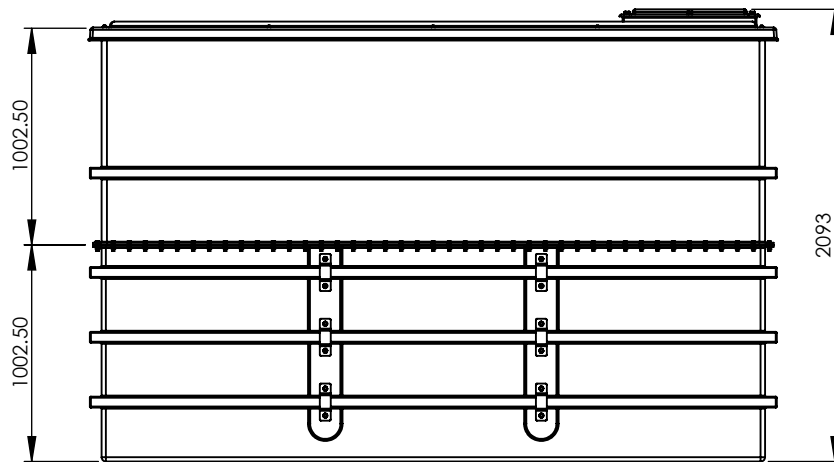
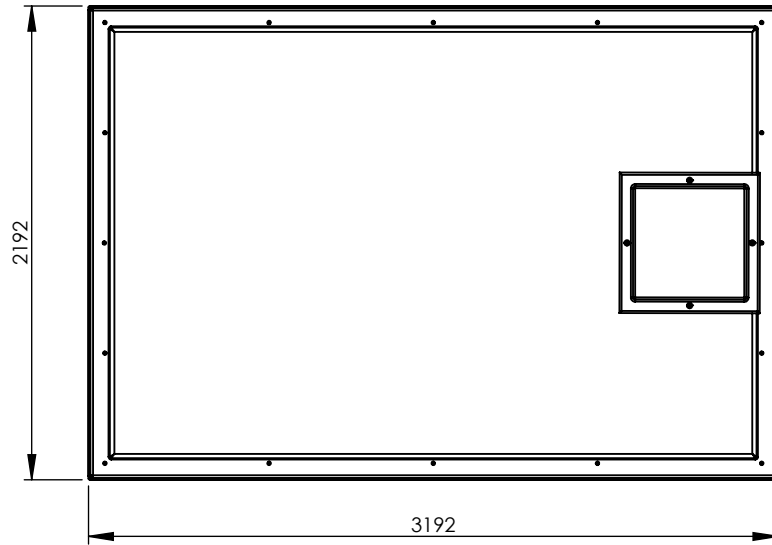
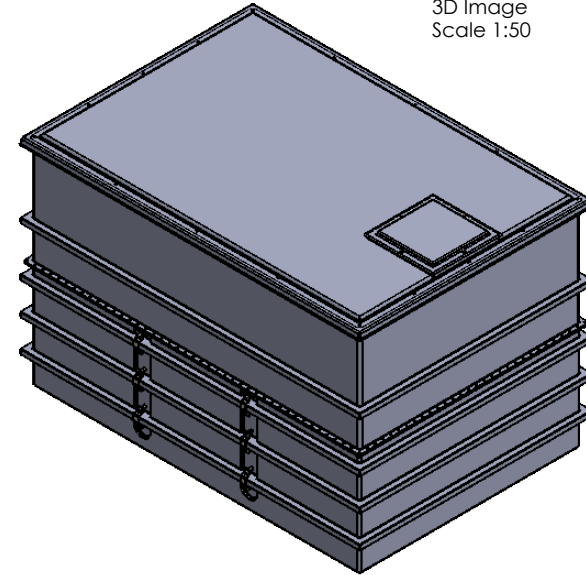

TITLE
PW12000.INS-2.AG

DRAWN BY C.MORRIS DATE 28/11/2017

CUSTOMER CUSTOMER

NOTE:
All Tanks Direct tanks must be fully supported on a flat, level & continuous foundation providing structural support to the tank when full to maximum operating capacity. It is essential that the user refers to the conditions of installation document prior to the installation of the tank. Under no circumstances should the tank body be used to provide support to pipework and ancillary items. The tank lid is a structural part of the tank and must be in place and fitted correctly when water is contained within the tank.

DESCRIPTION:
PW12000-2 piece cold water storage tank suitable for AG/AF Air gap

A4

ALL DIMENSIONS IN MM - DO NOT SCALE

DATE	VERSION	NOTES
07/09/2017	A	FIRST ISSUE

TANK SPECIFICATION :

INTERNAL DIMENSIONS	3000 x 2000 x 2000mm
EXTERNAL DIMENSIONS	3192 x 2192 x 2093mm
NOM. CAPACITY	12,000 Litres
DRY WEIGHT	520 KG Estimated
INSULATION THICKNESS	25mm
WRAS CERT. NUMBER	1310072
MATERIAL	GRP



SCALE:1:35

SHEET 1 OF 1