



GRP Technical Installation manual

Contents

- Safety, Installation guide
- Service Specification
- Concrete Specification
- Lift height
- Vibration
- Impact of Concrete On Discharge
- Loadings
- Transportation, unloading and Storage of Tanks
- Pre Installation Inspection
- Control of Groundwater
- Access Shaft Extensions
- GRP tank Plantroom tank

Technical Data Manual

A comprehensive manual covering handling and installation, This includes general underground tanks, Separators, and package pump station.

With extensive GRP knowledge and experience, we will provide you the customer, with quality GRP products with excellent service along the way.

2005 Edition
Amended March 2018

INSTALLATION GUIDANCE NOTES

SAFETY

Concrete Surround

Note:

These guidance notes refer only to the installation of concrete surround underground tanks.

These guidance notes cannot provide specific, site-related installation instructions.

If in any doubt whatsoever about any aspect of the installation, please contact

This manual contains basic information on the installation, operating and maintenance and should be followed carefully. It is essential that these instructions are carefully read before installation or commissioning by both the installation crew as well as those responsible for operation or maintenance.

The operating instructions should always be readily available at the location of the unit.

Identification of safety and warning symbols



WARNING!

Non-observance to this warning could damage the unit or affect its function.

Qualifications of Personnel

An authorized (certified) electrician and mechanic shall carry out all work.

Safety regulations for the owner/operator

All government regulations, local health and safety codes shall be complied with.

All dangers due to electricity must be avoided (for details consult the regulations of your local electricity supply company).

Unilateral modification and spare parts manufacturing

Modifications or changes to the unit/installation should only be carried out after consulting with the manufacturer. Original spare parts and accessories authorized by the manufacturer are essential for compliance.

The use of other parts can invalidate any claims for warranty or compensation.

Service Specification

These tanks are designed to be installed below ground and completely surrounded with concrete.

Generally, the depth from finished ground level to the top crown of the main shell should be no more than 2 metres. This may vary dependent upon ground water conditions.

Deeper inverts may be accommodated on a standard shell providing the water table level does not exceed 2 metres above the top crown of the main shell.

For deeper burial with high water table conditions heavy duty shells are available.

Should you be in any doubt regarding suitable shell application please call our technical sales office on 0333 240 9935

If the tank is installed outside these parameters, it may suffer irreparable damage.

Concrete Specification

The specification for the concrete mix to surround the tank may be taken from BS 5328: Part 1: 1991 (including amendments), taking into account the site conditions and application requirements.

For a typical non-structural application in non-aggressive soils a standard mix ST4 with a 50mm slump is generally suitable, but also permits the equivalent designated mix GEN3 to be specified as an alternative.

If for non-typical applications, structural or other reasons a higher than normal designation is required, the purchaser of the fresh concrete can use table 6 in BS 5328: Part 2: 1991 (amendment 8759/October 1995) for guidance.

Lift Height (Rate of Rise)

Determine the lift height (m), or rate of rise (m/h) for the specific concrete type used, to ensure that a design pressure (P_{max}) of 15kN/m² on the tank is not exceeded.

Vibration

The design of the tank assumes minimal compaction of the surrounding concrete. Where necessary, this may be extended to include light internal vibration. Never use deep revibration which will substantially increase the pressure on the tank, possibly causing failure.

Impact of Concrete on Discharge

The effects of impact on discharge are considerable.

These are controlled by the vertical form height, the tank diameter and the method of discharge.

Under no circumstances should concrete be discharged directly onto the tank.

Loadings

If the tank is installed in an area where traffic or other superimposed loadings can be applied, consult a structural engineer for the design of a reinforced concrete slab to prevent the load being transmitted to the tank (or its concrete surround). If this slab is constructed immediately above the tank, it should be separated from the concrete surrounding the tank by a compressible material.

Transportation, unloading and storage of tanks

1. Tanks must be held down during transportation using nylon straps, do **NOT** use cables or chains to hold tanks.
2. Do **NOT** over tighten straps to cause deformation of the tank shell.
3. Tanks are best lifted by crane and webbing lifting straps – do **NOT** use chains or wire ropes in contact with the tank.
4. We highly recommend the use of a lifting beam for tanks longer than 8 meters.
5. Smaller tanks may be lifted with other suitable site equipment, but greater care is needed to control the lift and to ensure the tank is not damaged.

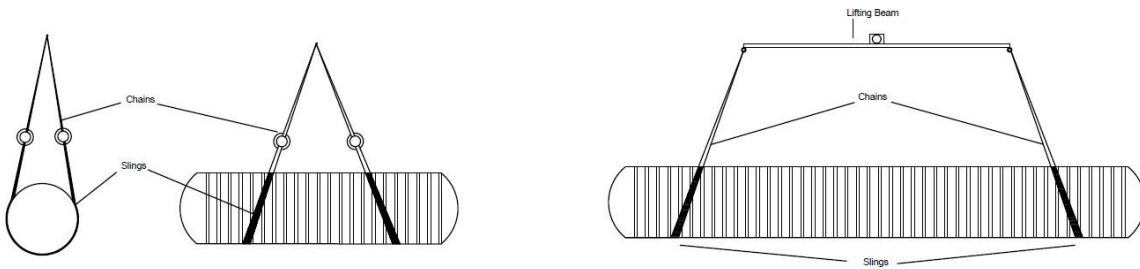

6. Move tanks only by lifting and setting, do **NOT** drag or roll.
7. Do **NOT** drop or roll tanks from truck
8. Place tanks carefully onto a smooth level even surface, free from rocks, large stones or other debris that could cause point loads.
9. Chock tanks using tyres, sandbags or similar to prevent rolling

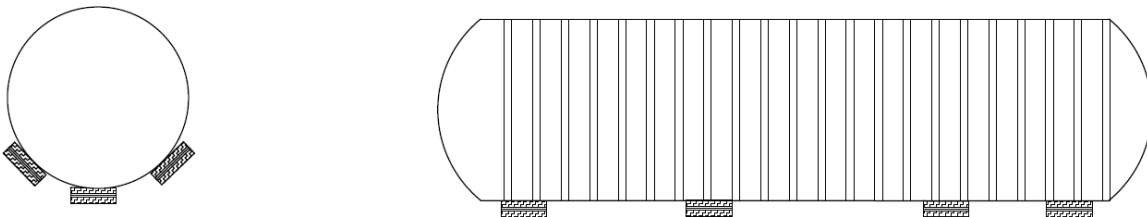

10. In high winds conditions, consideration should be given to strapping down the tanks to prevent damage

Pre-Installation Inspection

1. Tanks should be subject to a visual inspection prior to installation
2. Special consideration should be given to lifting straps positions
3. Any damage should be notified to the delivery driver and to the supplier
4. Do not attempt to carry out any un authorised repairs, as this will invalidate the warranty on the tank
5. Check for fractures to the shell or ribs, de laminations, scratches or abrasions deeper tanks 1.5mm, stress cracks or star crazing
6. Check invert depth is correct and inlet and outlet pipe orientations are correct

Installation procedures must be in accordance with the health and safety at work act 1974, and others relevant legislation. Your procedures must also align with good building practice.

1. Excavate for the tank, allowing sufficient clearance for the minimum concrete surround thickness as shown in the table below, whilst also taking into account any shoring/ trench supports used. The depth of the excavation is determined by the inlet and outlet pipe invert levels relative to the bottom of the tank, and allowing for the minimum base thickness shown. Dimensioned details of the separator can be taken from the relevant drawing. Ground instability at formation level e.g. running sand may necessitate over excavation and stabilisation with hard core or blinding concrete.

NOTE: check the depth to the base slab is within the service specification requirements for the tank.

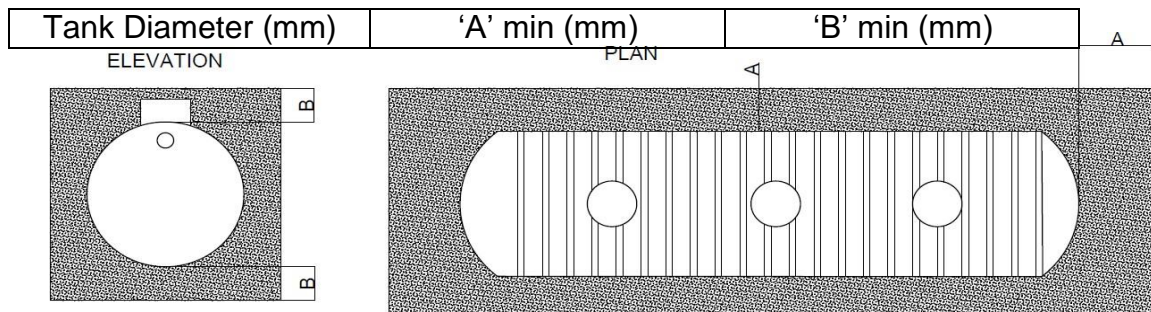

Tank Diameter (mm)	'A' min (mm)	'B' min (mm)
1000	150	150
1200	150	150
1500	200	200
1800	250	250
2500	300	300
3000	300	300
4000	300	300

Maintain a completely dry excavation until the final pour of concrete has set. Failure to do this may result in voids beneath the tank and subsequent tank failure.

1. Pour the concrete into the bottom of the excavation to form a level and smooth base onto which the tank can sit. This should be to the minimum thickness given in the table above.
2. Place the tank onto the concrete base, while the concrete is still wet, and determine the correct orientation for the tank inlet(s) and outlet(s), i.e. the higher pipe on the tank is to be connected to your downstream (outlet) pipe work. Connect and seal your pipe work to the tank, checking alignment, and ensure that there is an adequate and correct fall for each pipe.
3. Fill each chamber of the separator with clean water to depth of 300mm and recheck the pipe work levels. Commence backfilling evenly around the tank with concrete ensuring there are no voids, particularly at the bottom of the tank shell. Continue filling the chambers with water whilst evenly backfilling with concrete ensuring that the progressive water level is no more than 300mm above concrete level.
4. Connect and seal turret extensions prior to completing the concrete encasement of the main tank to the height shown on the table. Allow this concrete to set.
5. Using appropriate formwork, continue pouring concrete around the tank superstructure (i.e. bypass chamber, access turrets) in lift heights not exceeding 500mm, allowing the initial set between each lift.

NOTE: Never increase the lift height or accelerate the rate of rise for the concrete type used, or allow the concrete to be compacted to an extent which will cause any part of the tank superstructure to distort. If you contravene this warning you will cause damage to the tank.

6. Complete backfill to ground level using free flowing material. Trim all access turrets and prepare suitable footings for each manhole frame ensuring that any loads on the covers are not transmitted to the tank access turrets or access extensions, if fitted.

Control of Groundwater

Tanks must not be subjected to buoyant forces during installation, taking account of ground water levels and surface water run-off, and their accumulation in the tank pit, even if tanks are anchored.

The excavation should be maintained dry by pumping or whatever suitable means until the concrete surround is cured.

Access Shaft Extensions

Access extensions shall be surrounded with concrete poured in 500mm lifts allowing initial set between each lift. The pressure from concrete placed in higher lifts may cause access extensions to distort or collapse.

Please note that loose shafts should be sealed using silicon sealant Sikaflex -291 or similar prior to installation to prevent ingress of ground water under high water table conditions. It is the contractor's responsibility to ensure a watertight seal.

GRP tank Plantroom tank

The installation of a combi GRP tank and plantroom is carried out to the same sequence of a standard installation.

The only main difference is that the plantroom side of the combi tank is not filled with water for ballast.

The water tank side is filled as per the instruction, the plantroom side has been designed to be installed without the water ballast. It is recommended that the tank is strapped in to the excavation to avoid any buoyancy please see the detail below.

BUOYANCY & ANCHORING

Where depth of cover over the tank exceeds 70% of the tank diameter, it will not require mechanical anchoring in worst case conditions of empty tank with tank pit flooded to ground level. If depth of cover is less than this, then mechanical anchoring is required for worst case conditions.

Two methods are possible:-

a) Reinforced Concrete Anchor Slab

Reinforced concrete anchor slab of minimum thickness 200 mm, sized to cover the excavation area.

The slab should incorporate webbing anchor straps.

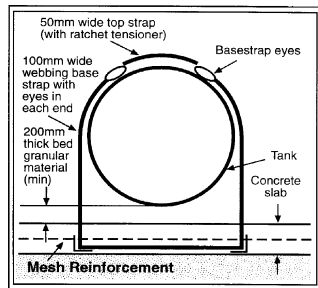

b) Concrete Deadman Anchors

Reinforced (two 20mm steel bars) concrete beam (pre-cast or in situ) each side of the tank of equal length to the tank, and with section as shown below. Use Environmental Construction Solutions Ltd's webbing anchor straps as illustrated below:-

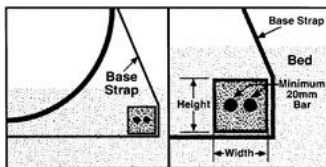

Tank Diameter mm	Minimum Height mm	Width mm
1800	300	300
2500	300	300
3000	300	450
4000	200	900

Deadman size Deadman should not lie in tank shadow.