

1 x 0.5m PANELS TO BE USED

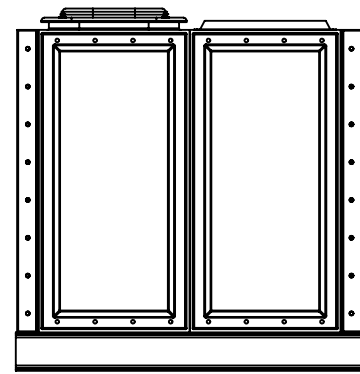
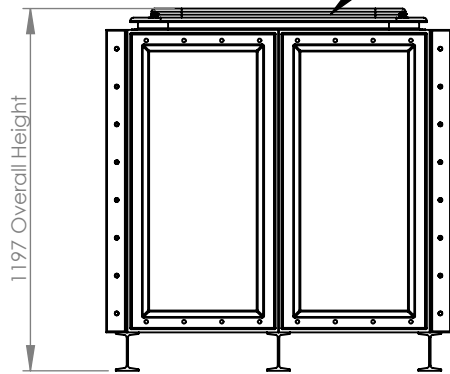

TITLE PW.1x1x1.IFB.AG.500	
DRAWN BY J. Ellison	DATE 10/02/2023
CUSTOMER CUSTOMER	

NOTE:
Tanks Direct sectional tanks must be fully supported on a flat, level & continuous foundation which provides structural support to the tank when full to maximum capacity. It is essential that the installer and/or user refers to the conditions of the installation document prior to the installation of the tank. Under no circumstances should any part of the tank structure be used to provide support to pipework and/or any ancillary items.

ALL DIMENSIONS +/- 5mm UNLESS OTHERWISE STATED

DESCRIPTION:
PW.1x1x1.IFB.AG.500 Sectional cold water storage tank c/w access manway to provide an AG Air gap - 1 X 0.5m PANEL SIZE

ALL DIMENSIONS IN MM - DO NOT SCALE

DATE	VERSION	NOTES
10/02/2023	A	FIRST ISSUE

TANK SPECIFICATION :	
INTERNAL DIMENSIONS	1000 x 1000 x 1000mm
EXTERNAL DIMENSIONS	1150 x 1140 x 1197mm
NOM. CAPACITY	1000 Litres
INSULATION THICKNESS	50mm
MATERIAL	Hot press moulded GRP



SCALE:1:25 SHEET 1 OF 1