



# E-Series O&M Manual

Installation, Operation & Maintenance  
Instructions



## 1. Introduction

We strongly suggest that the operator carefully reads and follows the information contained in this instruction manual for the frequency converter.

### Symbol used:



This symbol indicates **high voltage hazard**. It draws attention to components or procedures that could represent a potential danger to the health and welfare of the operator.



This symbol is used to draw the operator's attention to situations of potential danger for people or for operations that could cause damage to the product.

## 2. Special warnings regarding the frequency converter.

We strongly suggest that the operator carefully reads and follows the information contained in this instruction manual for the frequency converter.

**The FREQUENCY CONVERTER should NEVER be opened or tampered with and guards that come with it should never be removed.**

The frequency converter must be installed, adjusted and maintained by qualified personnel who understand the risks involved.

The booster set is designed to start automatically. Make hydraulic connections and to prime the pumps before making any electrical connections.

The connection of the control panels must be performed by a qualified electrician in accordance with the present electrical standards.

The booster set and control panels must be connected to an efficient earthing system in accordance with the electrical standards of the country in which it is installed.

The connection of the earth must be performed first.

The connection of the alarms can distribute power even when the frequency converter is turned off. Ensure that there is no residual voltage on the terminals of the alarms. All the power terminals and other terminals must be inaccessible after installation is completed.

The maximum output frequency must not exceed the design frequency of the pump being controlled. Operating at a frequency higher than the allowable frequency can cause higher current absorption and damage to the device.

If it is necessary to remove the frequency converter, remove only the covers required in order to disconnect the electrical cables. Take care not to damage the electronic cards.

Failure to comply with the safety regulations not only causes risk to personal safety and damage to the equipment, but also invalidates every right to assistance under warranty.

The Booster sets are designed and built to ensure a constant pressure, specifically suitable for domestic applications and small or medium systems for civil, agricultural or industrial uses. Booster sets strengths and benefit: constant pressure, low noise operation, low running costs, low water consumption, protection against dry running. It's recommended to use the sets with pressure vessel.

### **Construction features**

- Nr. 1, 2 or 3 electric pumps WRAS approved
- Variable speed inverter designated for each pump
- GRP pre insulated water storage tank
- Stainless steel manifolds, threaded
- Ball valves WRAS approved on discharge of each pump
- Check valve included for each inverter with flow passage
- Stainless steel end caps for manifolds
- Pressure vessel WRAS approved

### **Electrical section**

- Flow passage Inverter module on the discharge line of each pump.

The FLOW PASSAGE INVERTER system is a device installed in line with the pump's discharge outlet. It includes a pressure sensor, a flow sensor and an electronic inverter. Installed on the outlet discharge line of each electronic pump, it controls the pump's speed rotation which is connected and maintain a fixed pressure at the set flow rate.

### **Functioning**

In case of pressure drop in/reduction, caused by water withdrawal, the first pump starts to satisfy at the requested flow rate. In parallel inverter installations (booster sets with two or three pumps), the MASTER inverter fully controls the SLAVE inverters, which can operate independently only when the MASTER is turned off.

In case of standard operating is possible: to display the system pressure, to display motor absorption (if the motor is running), to display the power supply voltage (if the motor is not running), to display the working frequency, to display any pump alarm conditions, to put the pump out of service, to set the parameters . In units with more than one pump, the MASTER inverter allows you to check that the inverters communicate correctly using the system status display.

### **Dry running protection**

If the system has been stopped due to lack of water, the inverter makes automatic and predefined times to re-attempt starting.

In case of use under inverter and with membrane tanks, is necessary a total volume of the tank (expressed in litres) not lower than the 10% of the maximum single pump flow rate. The pump sets are supplied complete with installation / maintenance instructions and wiring diagram.

The present manual is aimed at giving the necessary information regarding the installation, use and maintenance of booster sets with variable speed by flow passage

frequency inverter consisting of various pumps.

It is vital that the user reads this manual prior to using the system. Improper use may cause damage to the machine as well as the lapse of the guarantee. **When requesting information or spare parts from our Sales Department, quote the exact identification code of the model together with the manufacture number.**

This manual, along with any other manuals and other documents which are delivered with the booster set, is an integral part of the operating instructions.

This manual aims to provide information and instructions essential to adequately perform all activities related to the use of the product purchased. This manual, and documentation, are intended to be viewed by all persons involved in the life cycle of the booster set and therefore must be accessible to the user.

**Compliance with all safety requirements is an obligation of the customer.**

The following instructions and requirements relate to the standard operations; for instructions, situations and events that are not covered in the present manual or sales documents, contact our assistance service.

**The installation must be designed and carried out only by qualified technicians; Errors in the installation or use can cause serious damage to the equipment, the user system and the people involved.**

Do not make any action, maintenance, repairs or modifications that you do not have specific knowledge or received detailed instructions. If doubts remain, after consultation with the following paragraphs, surveyed Fluid Water Solutions Ltd. All operations must be carried out while respecting the safety rules.

**Remember that you respect the regulations in force in the country of installation: if different rules are in force on the same topic, you should always consider the more stringent requirements.**

Our products have been manufactured in accordance with the applicable safety standards in force for which it is recommended the use of all devices or notices in order that the use does not cause injury to persons or damage to belongings.

Our products were designed for the specific use intended, **THEREFORE ANY OTHER USE THAT IS DIFFERENT AND NOT IN ACCORDANCE WITH WHAT INDICATED, EXEMPTS FLUID WATER SOLUTIONS LTD FROM RISKS** that may occur.

The modification of both mechanical and electrical parts of the machine is strictly prohibited. The non-compliance exempts Fluid Water Solutions Ltd from any responsibility. **The responsibility of any operation that has not been authorised in writing shall fall upon the executor, inasmuch that they become the manufacturer.**

**Fluid Water Solutions Ltd hold no responsibility whatsoever for possible damage to the booster set, persons or belongings. The individual safety standards of the country of destination should be abided by during the use of equipment.**

**READ THE INSTRUCTION MANUALS OF EVERY PUMPS, MOTORS, CONTROL PANELS AND OTHERWISE OF ALL COMPONENTS. FOLLOW THE PROVISIONS OF THE SAFETY AND PERFORM THE PLANNED MAINTENANCE RECOMMENDED IN THE INSTRUCTION MANUALS.**



Danger, Risk of electric shock



Warning

- The set must be fitted in a well ventilated place, protected from unfavourable weather conditions.
- When handling the set, lift it by the base.
- Do not lift the set by the delivery manifold: risk of damage to the inverter modules.
- Position the set in such a way that any maintenance jobs can be carried out without difficulty.
- Ensure that the system pipes are independently supported and do not weigh down on the set manifolds so as to avoid deformation or breaking of any of its components.

It is also advisable to insert vibration-damping couplings on the system manifolds.

Make the intake section following all the precautions necessary to keep load losses to a minimum and to avoid the formation of air pockets, for example:

- Position the set as close as possible to the power supply source.
- Consider a suction pipe diameter never smaller than that of the manifold.
- Lay the suction pipe horizontally or sloping slightly upwards towards the set.
- Avoid using elbows or couplings that cause sudden changes in direction. If necessary, use bends with a wide radius.

Installation must be performed by skilled and authorised installers. During installation, apply all safety behaviours issued by the competent bodies and suggested by common sense. Install the unit in a dry well-ventilated place. Rest the unit on a flat, regular and solid surface (rubber feet) or disassemble the rubber feet and fix the unit to the base using the relevant screws. Vibrations must not occur during functioning. The unit can only be installed in the horizontal position. In the applications with positive suction head, the suction pipe must not be smaller than that of the intake manifold. In the applications with negative suction head, in particular cases there may be the necessity to replace the intake manifold with an individual supply for each pump, in order to prevent preferential flows to

one or several pumps. Generally, in negative suction head applications, the intake pipes must be as short and straight as possible, they must have a diameter greater than or equal



**RISK OF ELECTRIC SHOCK**



**WARNING**

to the diameter of the pump intake (or the manifold if present). They must also be supplied with foot-valve and have a slight slope to the pumps, to prevent the formation of air pockets. Functioning with leaks in intake can damage the unit pumps. Fix carefully the piping in order not to transmit stress of any type to the pump. Fasten the piping to the respective manifolds, without excessive force so as not to cause damage. Booster sets can be shifted in different ways depending on the configuration of the machine and equipment available to the installer.

The units are delivered ready for power supply connection, which must be carried out by a skilled, authorised installer, in compliance with the Standards in force in the country of installation. During installation, apply all safety behaviours suggested by law and common sense. Make sure that the electric power supply network is protected by ground connections in compliance with Standards.

Check the correspondence between the plate data and line nominal values. Before making the connections, make sure that the ends of the line wires are not live. Make the connection when you are sure of the existence of an efficient ground circuit. The ground wire must be longer than the phase wires and must be the first to be connected during assembly and the last to be disconnected during disassembly. The installation of a differential switch is recommended, whose nominal functioning differential current does not exceed 30 mA (use highly sensitive differential circuit breakers 30 mA, in Class A or AS).

**For booster sets with single phase power supply (versions "M/T")** connect power supply directly to the inverter, as follows:

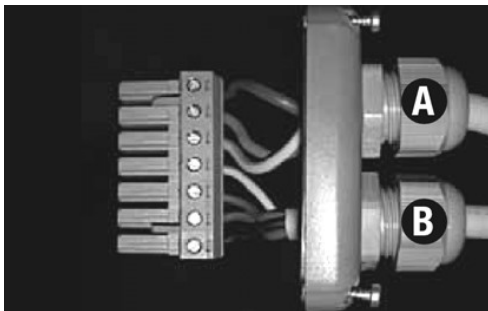

**A: connect power supply cable to inverter (see picture). B: motor output connection (already connected).**

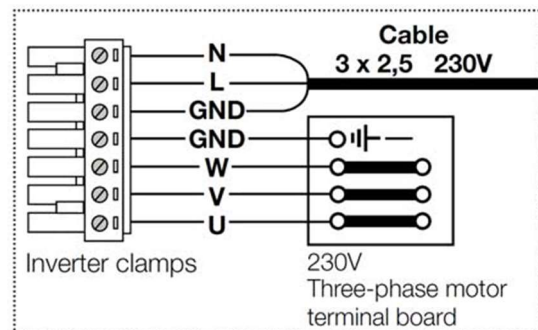

Single-phase power supply: the inverter power supply line voltage can vary in a range between

+/-10% of the plate power supply voltage. The power supply cable must have 3 wires (2 phase + ground), the section of the cable to use, for line length up to 30 m, must be at least 2.5mm<sup>2</sup>. The connection to the power supply line will be performed on the L, N and GND clamps of the inverter (see upper picture).

**For booster sets with three-phase power supply (versions "T/T")** connect power supply directly to electric protection control panel containing thermal magnetic switch.

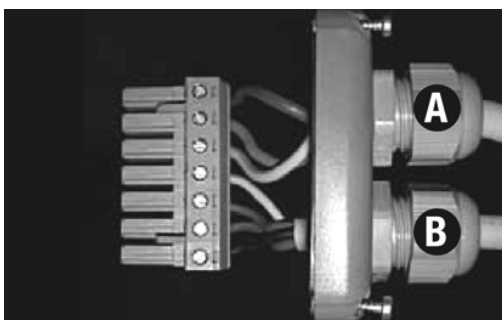

**A: inverter power supply connection (already connected). B: motor output connection (already connected).**

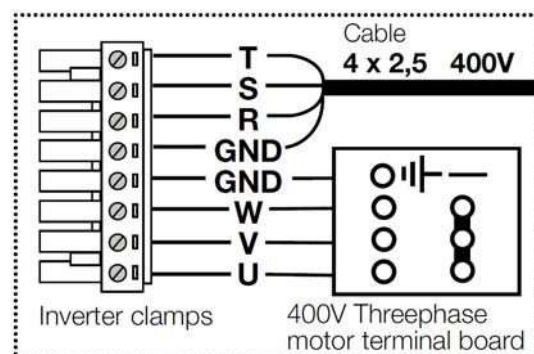

For three-phase supply: Make sure the rated current absorbed by the motor is compatible with the details on the inverter plate. The power voltage of the installed electric pump

motor must be 400V three phase.

### Control Card:

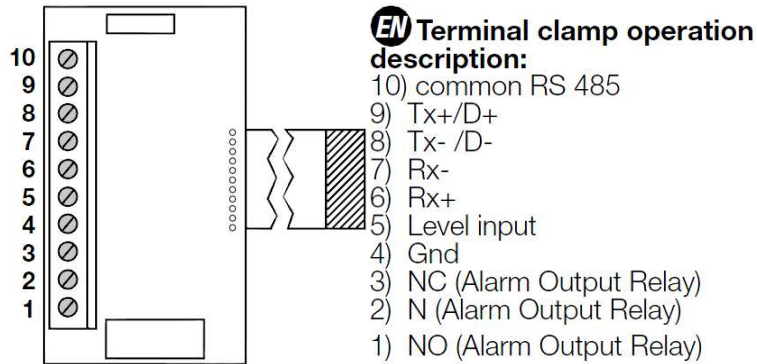

### Signal Connections:

The expansion board, located in the back of the inverter, holds the signal connection terminal clamps

**RS485 signal:** to communicate between inverters or between the inverters and the panel. These the contacts shown in points 6, 7, 8, 9, and 10.

**Alarm signal output:** signals if there is a stop due to a fault. The signal can be connected to both NC and NO control. The maximum load for connection is 5A at 250 V AC. These are the contacts shown in positions 1, 2, and 3.

**Level signal input** (or other input signal): This allows a level sensor to be connected which stops operation if the signal is not active. The level sensor connected must provide an ON/OFF contact. These are the contacts shown in positions 4 and 5.

**Connection of signal between inverters (RS485 signal):** With reference to the figure shown above, proceed in the following manner:

- Connect terminal 9 of the inverters together
- Connect terminal 8 of the inverters together

The signal wire must have 2 conductors and the minimum wire cross-section is 0.5 mm<sup>2</sup>. The maximum distance between inverters connected together in parallel must not be greater than 10 m.

**Connection of the Alarm Signal (MASTER inverter):** Referring to the figure shown above, the terminals to be connected with the signal wire (two conductors, minimum cross section 0.5 mm<sup>2</sup>) are 2 and 3 for NC operation, and 2 and 1 for NO operation.

**Connection of level sensor or other input signal (MASTER inverter):** Referring to the figure shown above, the terminals to be connected with the signal wire (two conductors, minimum cross-section 0.5 mm<sup>2</sup>) are 5 and 4.

E-SERIES is a speed regulator powered in single-phase and three-phase for electric a.c. single-phase and three-phase motors.

- It keeps the system pressure constant at a value defined by the user, adapting pump performance to instant request, changing the number of motor revs.
- It carries out continuous controls on electric and functioning parameters, saving the



pumping unit from all common anomalies (over-currents, dry running, etc)

- It works in stand-alone configuration or in parallel with other inverter via serial connection (optional module).

- It adapts to all type of systems, even existing, while it simplifies design and complexity of new systems, thus reducing costs, because it prevents the use of pressure switches, important expansion vessels, electric control boards and non-return valve.

- It activates the electric pump with starting ramps at a progressive speed, which limit current peaks, thus lengthening the life of the motors and allowing a great energy saving.

- 1 - Control system
- 2 - Removable electric connector
- 3 - I/O power cable bushing
- 4 - Power board cover
- 5 - Three-piece joint
- 6 - Technical data plate
- 7 - master switch (only versions "M/T")
- 8 - Fuse (only versions "M/T")
- 9 - Non-return valve unit

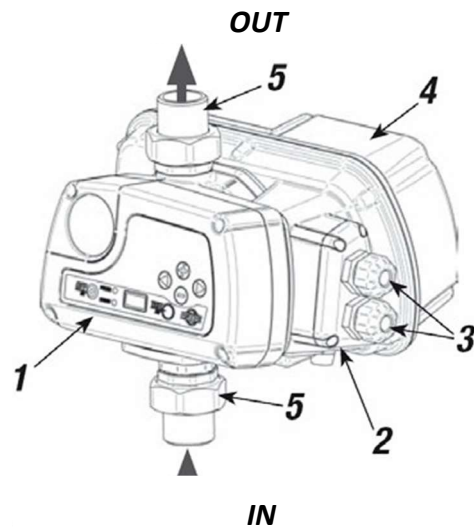

#### GENERAL TECHNICAL DATA

- Power supply voltage: singlephase 230-115Vac; threephase 400Vac

- Frequency 50-60 hz

- Maximum working pressure: 10 bar

- Working position: vertical, with intake from the bottom and top exit.

E-SERIES keeps the system pressure constant (at a value defined by the user) on variation of the flow rate requested, adapting pump performance, via variation of the number of electric motor revs. The dimensioning of the internal hydraulic passages and the careful hydraulic design allow the inverter to elaborate flow rates up to 200 l/min with very small pressure drops. On the booster set the E-SERIES are connected in parallel in Master / Slave 1 / Slave 2 (Depending on the number of pumps). In this configuration the system, in addition to keeping the pressure constant by the frequency modulation of the motors, manages the alternation of starts, in order to standardize the use of pumps. In Master / Slave configuration the settings will be executed only on controller defined as Master. The controller defined Slave will receives automatically settings from the controller defined Master. If master E-SERIES is turned off, the slave E-SERIES works in a "stand alone" mode.

**For the settings of the E-SERIES please refer to attached document.**



**Before removing the inverter cover or starting interventions on it, the system must be disconnected from the mains electricity and you must wait 5 mins until the intermediate circuit condensers, which can reach voltages up to 800V, have the time to discharge via the built-in discharge resistors.**

### **EMERGENCY STOP**



**An emergency stop can be performed while the inverter is running, by pressing the START/STOP key. Installations with parallel inverters only the MASTER inverter blocks the system. An emergency stop is performed by pressing the START / STOP switch on the MASTER inverter. If the START / STOP switch on a SLAVE inverter is pressed the only effect is that single inverter is stopped; not the entire system.**

Before starting up, please read carefully this Manual and the instructions of E-SERIES. In this way incorrect settings and manoeuvres are prevented, which could cause functioning anomalies. The system must never be started dry for any reason. Dry running of the pumps, even for very brief periods, can cause irreversible damage to mechanical sealing and internal rotating couplings. Priming must be performed before system start-up. Whenever the equipment is powered by the mains (upon initial installation, following voluntary shutdown or in the event of a power cut and the subsequent return of power), it will enter a START phase lasting about ten seconds. Because all of the operating parameters - including its alarm/ blocking conditions - are stored on a non-volatile memory, the E-SERIES will resume the same operating conditions as when it was last shut-down (including in the event of accidental power supply failure) after this 10-second start phase. Where the E-SERIES was ON when the last shut-down occurred, the pump will activate after these 10 seconds if the pressure detected is less than the predetermined threshold; you can put the group OUT OF SERVICE prior to the automatic start-up by hitting START/STOP. Where the E-SERIES was OFF when the last shut-down occurred, the group will remain OUT OF SERVICE following the 10-second start phase. To start-up, hit START/STOP and confirm. In parallel inverter installations, the MASTER inverter fully controls the SLAVE inverters, which can operate independently only when the MASTER is turned off.

### **Priming**

A pumping system must never be started dry for any reason. Dry running of the pumps, even for very brief periods, can cause irreversible damage to mechanical sealing and internal rotating couplings. All pumps must be primed before starting the system by unscrewing the filler cap and filling the pump body with water (and the intake piping connected to it). When the operation has been completed, tighten the cap and start the pump, with the cut-off valve in flow almost completely closed, with the system in manual functioning mode (TEST).

If, after a few tens of seconds, the pump is not primed, switch it off, check that the intake is free, that there are

no air pockets upstream from the inlet, that the body is full of water and then repeat the operation. In the units, priming is performed for each individual pump, turning off the other pumps and performing the operations described above for each pump. To make priming of each pump simpler, E-SERIES suspends the SLAVE operation if the

MASTER is off (that is, the inverter returns to being completely independent) so that each inverter can be manoeuvred independently during the priming or test phase. Once all of the pumps are primed, the operative parameters can be set on the MASTER inverter. These are automatically sent to the SLAVE inverters when they are turned on.

### **Pressure Vessel**

A 24 ltr PressureWave vessel is normally fitted during production. A vessel should always be fitted on the discharge manifold close to the transducer to stabilize the pressure signal. Unlike conventional fixed speed systems a large vessel reservoir is not required. The vessel air charge should be maintained at 0.7 bar below the systems nominal operating pressure.

e.g. Target System Pressure = 5.0 bar  
Vessel Air Pressure = 4.3 bar



### **Inverter Settings:**

**See attached E-SERIES operating & maintenance manual.**

### **Pump Details:**

**See attached operating & maintenance manual.**

# Wiring Diagrams

## Twin Pump Single Phase

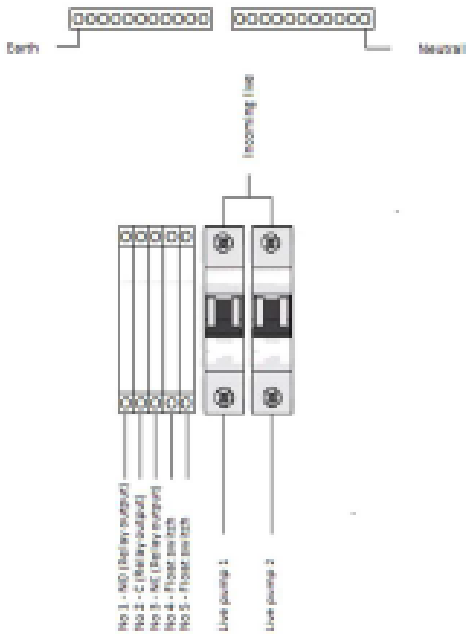

## Twin Pump Three Phase

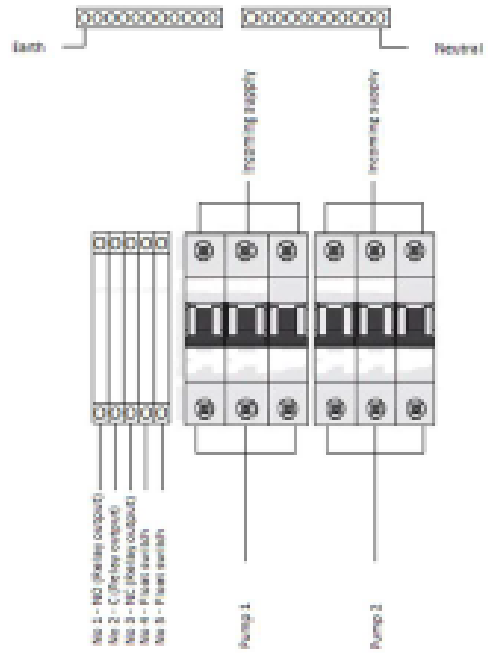

## Three Pump Single Phase

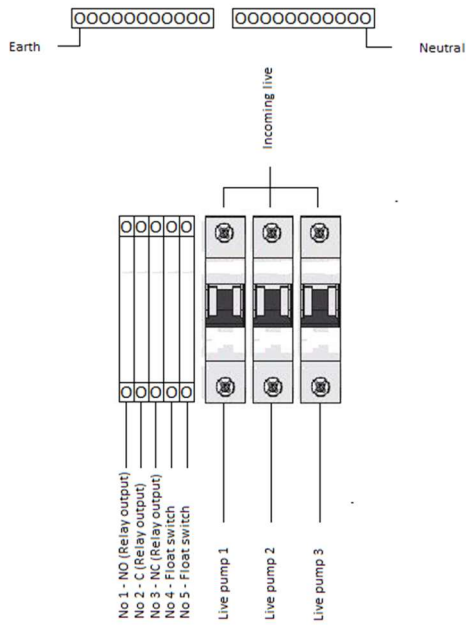

## Three Pump Three Phase

